



INSTRUCTIONS FOR USE



HYDRAULICALLY LIMITED FIBER OPTIC CABLE PULLER OPERATION MANUAL

HYDRAULICALLY LIMITED CABLE PULLER

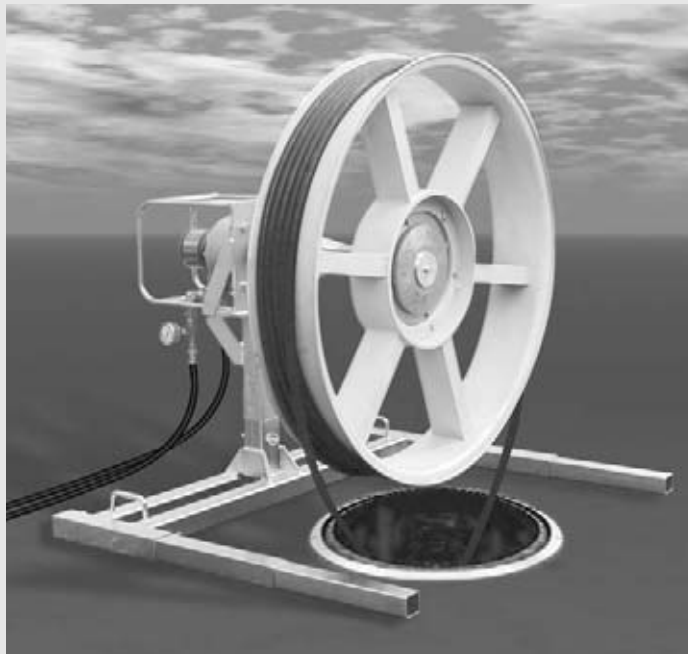

TABLE OF CONTENTS

1.0	GENERAL INFORMATION	2
2.0	SAFE OPERATING PRACTICES	3
3.0	TECHNICAL SPECIFICATIONS	3
4.0	COMPONENTS INCLUDED	3
5.0	OPTIONAL ACCESSORIES & REPLACEMENT ITEMS	4 & 5
6.0	OVERALL DIMENSIONS	6
7.0	KEY FEATURES	6
8.0	SETUP OF PULLER	6 & 7
8.1	HYDRAULIC CONNECTIONS	8
8.2	CALIBRATION	9
8.3	OPERATION	9
9.0	DISASSEMBLY AND STORAGE	10
10.0	CARE AND MAINTENANCE	10
11.0	TROUBLESHOOTING	11

1.0 GENERAL INFORMATION

The GMP Hydraulically limited fiber optic cable puller is designed for the underground placement of fiber optic cable. It uses a hydraulic control valve with an adjustable pressure relief valve to limit the hydraulic pressure to the hydraulic motor.

The GMP Hydraulically limited fiber optic cable puller comes complete with a self support frame, hydraulic motor, (2) 20 ft. hydraulic hoses and an adjustable foot control valve to control pulling tension and pulling speed.

Optional equipment includes a vehicle receiver mount with support jack for mounting to a 2" square trailer hitch. Also available is a portable hydraulic power unit with (2) 20 Ft. hydraulic hoses.

IMPORTANT PRECAUTIONS

Read and understand all safety instructions, warnings and procedures prior to using the GMP Hydraulically Limited Fiber Optic Cable Puller.

- ▶ THE HYDRAULICALLY LIMITED FIBER OPTIC CABLE PULLER IS NOT DESIGNED FOR, NOR INTENDED TO BE USED FOR THE MOVEMENT OF PEOPLE. NEVER USE THE PULLER FOR MOVING PEOPLE.
- ▶ THE HYDRAULICALLY LIMITED FIBER OPTIC CABLE PULLER IS NOT DESIGNED FOR, NOR INTENDED TO BE USED TO PULL CABLE AERIALY. NEVER USE THE PULLER TO INSTALL CABLE ARIELLY.
- ▶ ESCAPING FLUIDS UNDER PRESSURE CAN PENETRATE THE SKIN AND CAUSE SERIOUS PERSONAL INJURY.

2.0 GENERAL SAFETY PRECAUTIONS

1. Use a piece of cardboard to check for leaks. Do not use your hands.
2. Visually inspect hoses periodically and replace if worn or damaged. Do not exceed the working pressure of the hoses or fittings.
3. Maintain complete coordination with other members of the crew, giving them clear instructions by hand signal or reliable radio communication.
4. As much as possible, do not stand where there is the danger of being struck by the pulling rope or cable if it should fail or snag.
5. When working around the cable puller, do not wear loose fitting clothing that may become entangled with capstan and cause possible serious injury.
6. Keep hands safely away from capstan to prevent from getting caught or pinched.

3.0 TECHNICAL SPECIFICATIONS

Hydraulics Pressure: 2000-2250 PSI (138-155 bar)

Hydraulics Flow: 5-15 GMP (18.9-56.8 LPM)

Hydraulics Pulling capacities: 1,000 Lbs max. (455 Kg) line tension on up to a 42" (1067 mm) diameter capstan.

4.0 COMPONENTS INCLUDED WITH GMP #70483

- | | |
|--|-------------------------------|
| A. (1) hydraulic hoses (2) 1/2" diameter
x 20 feet with quick disconnect fittings | GMP P/N 30901 |
| B. (1) hydraulically limited foot control valve | GMP P/N 31117 |
| C. (1) hydraulic motor assembly. | GMP P/N 31115 |
| D. (1) self support frame. | GMP P/N 31116 |
| E. (2) extension legs for self support frame. | (Included with GMP P/N 31116) |
| F. (1) hitch pin with lynch pin attached. | (Included with GMP P/N 31116) |

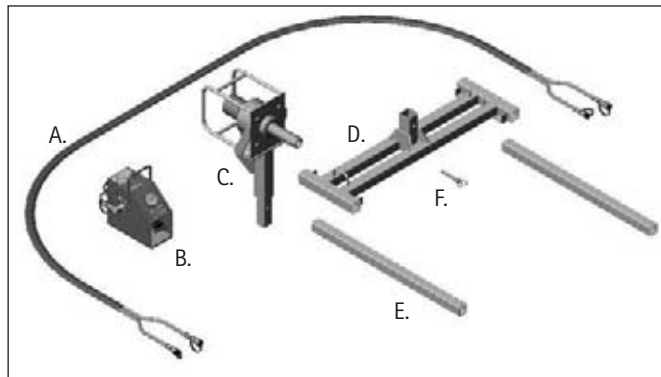

5.0 OPTIONAL ACCESSORIES AND REPLACEMENT ITEMS

(For other optional replacement items contact factory).



Trailer Hitch P/N 31219

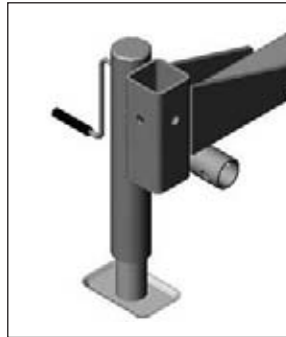

*Trailer Hitch with Support Jack
P/N 70484*



*Support Jack
P/N 31208*



Overhanging Socket P/N 70249



Star Shaped Floor Socket P/N 70250



Hydraulic Motor Assembly P/N 31115



Foot Control Valve P/N 31117



25" Fiber Optic Pulling Capstan
P/N 31208



32" Fiber Optic Pulling Capstan
P/N 70472



40" Fiber Optic Pulling Capstan
P/N 70478



Self-Supporting Frame P/N 31116



Portable Hydraulic Power Supply P/N 70487
(Includes two 20 ft. Hydraulic Hoses, Not Shown)

6.0 OVERALL DIMENSIONS

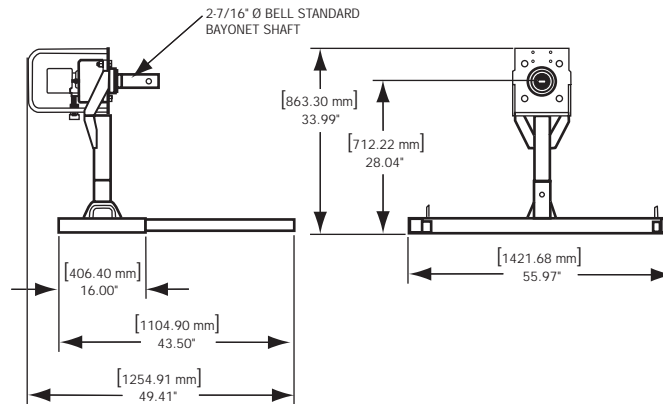

7.0 KEY FEATURES

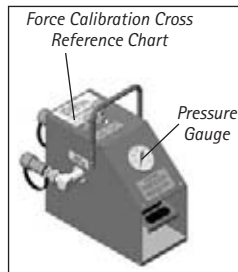

Foot Control Valve

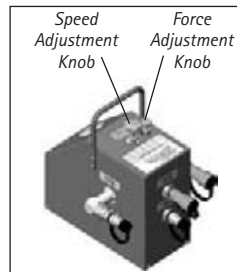

Foot Control Valve

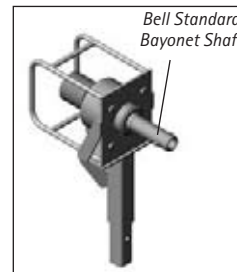

Hydraulically Limited Fiber Optic Cable Puller Motor Assembly

8.0 SETUP OF PULLER

Use caution when lifting hydraulically limited cable puller. Use only proper equipment and manpower. Improper lifting could result in injury or property damage.

1. Place puller stand on ground over pull box or manhole. Align the puller stand so the extension legs will straddle the pull box or manhole. Install the extension legs into the ends of the stand. Verify that extension legs straddle the pull box or manhole as shown. See fig. 1.



Figure 1

2. Place the hydraulic motor assembly into the puller stand socket with the shaft extending over the pull box or manhole as shown in Fig. 2. Install hitch pin to secure motor assembly in stand as shown in Fig. 2a.

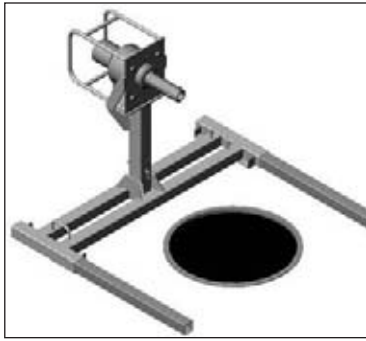

Figure 2

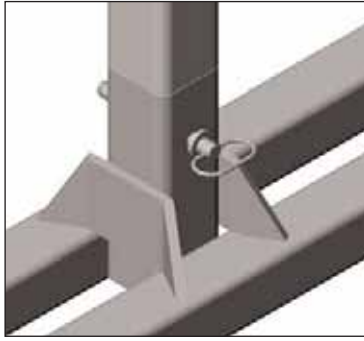

Figure 2a (Hitch Pin Detail)

3. Place foot control valve on ground near puller assembly as shown in Fig. 3.



Figure 3

Position puller over manhole as shown in Fig. 3a.

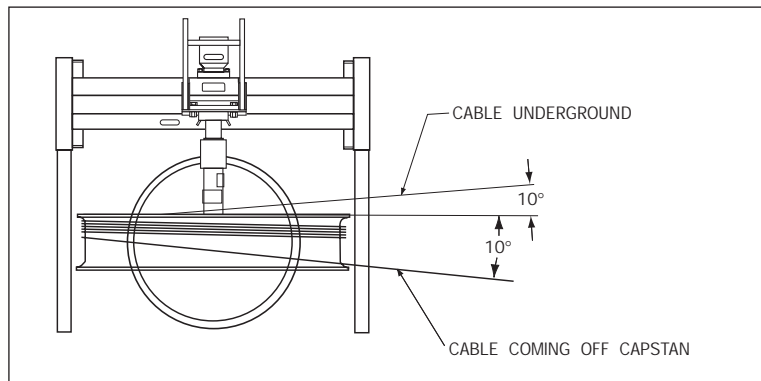

Figure 3a

8.1 HYDRAULIC CONNECTIONS

1. Clean all hydraulic couplings before making connections using a clean dry cloth. Connect hydraulic hoses from rear of foot control valve to hydraulic motor. See Fig. 4a and 4b. Connect male coupling on the hose to the corresponding female coupling on the foot valve and motor and the female coupling on the hose to the corresponding male coupling on the foot valve and motor.

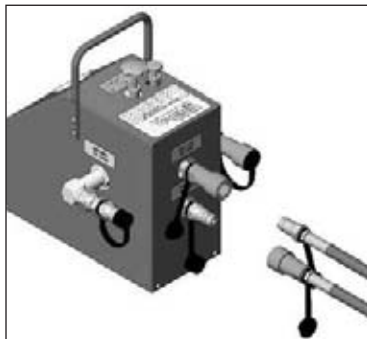

Figure 4a

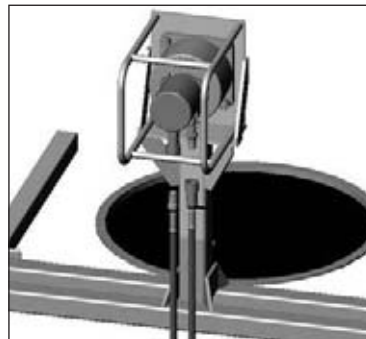

Figure 4b

2. Clean all hydraulic couplings before making connections using a clean dry cloth. Connect foot control valve to hydraulic power source using fittings on either side of foot control valve. Hydraulic pressure from power source to connect to fitting labeled "INLET PRESSURE" on side of foot control valve. Connect return line from power source to fitting labeled "RETURN TO TANK" on side of foot control valve. See Fig. 5.

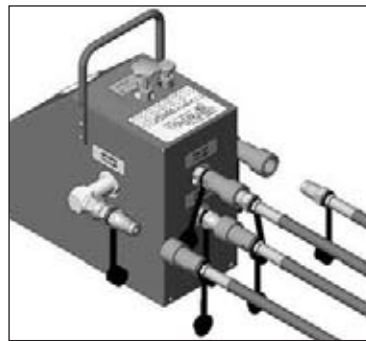

Figure 5

⚠ Important – In order for the foot control valve to operate properly it is important for the flow from the hydraulic power source to the foot control valve be connected as described in step 2. If the hydraulic flow from the hydraulic power source to the foot control valve is reversed the valve will not be able to limit the amount of force on the cable being pulled by the capstan resulting in possible damage to the cable.

3. Verify all connections then activate hydraulics. Depress foot control valve pedal. Hydraulic motor shaft should rotate in a clockwise direction when viewed from the front of the shaft.

8.2 CALIBRATION OF PULLER

1. Consult cable manufacture specifications for maximum pull rating and proper capstan size for cable being installed.
2. Refer to calibration chart for corresponding pressure setting for desired maximum pull and capstan diameter. For example, to set your hydraulic puller to a maximum pull of 600 Lbs. using a 32" diameter capstan, a pressure setting of 1,000 PSI is to be used. See chart below.

Hydraulic Pressure Setting (PSI)

Desired	Capstan Diameter				
	25"	30"	32"	40"	42"
Pull					
600 lbs.	700	900	1000	1300	1400
750 lbs.	800	1100	1200	1700	1800
1000 lbs.	1150	1500	1650	2200	2350

3. Calibrate your hydraulically limited cable puller as follows.
 1. Turn off the hydraulic power source.
 2. Disconnect hose from fitting labeled "OUTPUT TO PULLER"
 3. Turn on hydraulic power source and depress foot pedal.
 4. Adjust "Force control knob" until pressure gauge reads desired pressure setting based on capstan size from chart.
 5. Release foot pedal, turn off hydraulic power source and reconnect hose to fitting labeled "OUTPUT TO PULLER".

8.3 OPERATION OF PULLER

1. Install capstan onto hydraulic motor shaft and turn hydraulic power on.
2. Wrap pulling tape or cable around capstan in a clockwise rotation beginning at the outer edge of the capstan closest to the puller motor at least (4) times being careful not to over-lay the pulling tape or cable. Entire hydraulic puller assembly may have to be moved slightly to properly align the tape or cable being pulled with the capstan to avoid a cross-over condition of the pulling tape or cable.
3. In order to prevent it from becoming entangled with the capstan or hydraulic puller, the pulling tape or rope must be guided off the capstan. (See Figure 3a on page 7)

9.0 DISASSEMBLY AND STORAGE

1. Release foot control valve and turn off hydraulic power source.
2. Disconnect all hydraulic hoses and wipe off any residual hydraulic fluid from the quick-disconnect fittings.
3. Place caps and plugs onto quick-disconnect fittings.
4. Remove the capstan from the motor assembly by pushing the capstan inward towards the motor then rotate the capstan counterclockwise approximately a Quarter turn.
5. Remove the capstan from the drive shaft and store the capstan.
6. Remove the hitch pin securing the motor assembly to the stand and lift motor assembly from stand.
7. Remove the extension legs from the stand and place extension legs into the storage brackets on the stand assembly.
8. Store all components of the hydraulically limited cable puller securely.

10.0 CARE AND MAINTENANCE

General:

All components should be cleaned and securely stored to prevent damage.

Gearbox:

EP 80/90 GL-5 is the recommended lubricant.

Lubrication should be changed after the first 50 hours of operation, and every 500 hours thereafter.

Foot control valve:

Keep dirt and debris from inside of foot control valve housing.

Clean and place the caps and plugs onto the quick-disconnect fittings when not in use.

11.0 TROUBLESHOOTING

Problem:	Solution:
Motor assembly will not go into stand assembly.	<p>Check motor insert and stand receiver for damage or foreign materials preventing the insert from going into the stand receiver.</p> <p>Make sure hitch pin is not already installed in either the motor or stand assemblies.</p>
Cannot install hitch pin into motor and stand after assembly.	<p>Make sure the motor assembly is properly installed into the stand assembly, (See fig. 2 on page 8).</p>
Cannot engage the hydraulic quick-disconnect fittings.	<p>Hydraulic pressure has built up in the motor or hoses. Relieve the pressure by unscrewing one of the quick-disconnect fittings.</p> <p>Check quick-disconnect fittings for dirt or foreign materials and remove if present.</p>
Puller does not rotate when foot pedal is depressed.	<p>Check hydraulic power source is operating properly and any hydraulic shut-off valves or switches are open or on.</p> <p>Check the foot pedal for proper operation. Speed control valve knob may need to be adjusted to allow pedal to be depressed.</p> <p>Adjust force control knob by turning knob clockwise. Do not use tools to adjust – hand tighten only.</p>
Puller does not rotate in the desired direction.	<p>Rotate entire puller assemble to other side of man-hole or pull box, or reverse the hydraulic connections at the motor by removing the fittings then switch and re-install into motor.</p>
Cannot depress foot pedal.	<p>Adjust Speed Adjust knob counter-clockwise until pedal is able to move.</p> <p>Check for obstructions under foot pedal.</p>

For further assistance regarding your Hydraulically limited fiber optic cable puller, please contact General Machine Products at (215) 357-5500.

HYDRAULICALLY LIMITED CABLE PULLER

HYDRAULICALLY LIMITED FIBER OPTIC CABLE PULLER OPERATION MANUAL



GENERAL MACHINE PRODUCTS CO., INC.
3111 Old Lincoln Highway
Trevose, PA 19053-4996 USA
Tel: 215.357.5500 • Fax: 215.357.6216
Email: info@GMPtools.com
Web: www.GMPtools.com



GMP reserves the right, without notice, to make changes in equipment design or components as progress in engineering or manufacturing methods may warrant.
© 2002 General Machine Products Co., Inc.

Printed in USA GM 5842-50-1002-SS DOC 31223