

# GMP 2000 CABINET BALCONY #79281

## ASSEMBLY INSTRUCTIONS

Installation practice #2001-00054-OSP

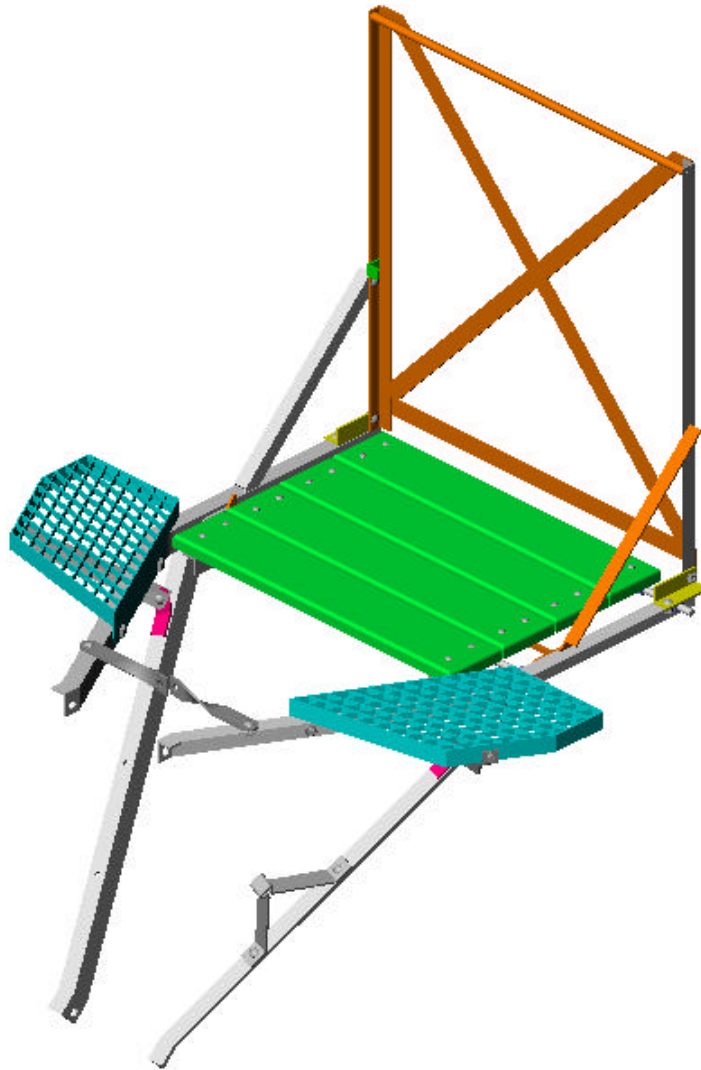

**TOOLS BUILT TO GO THE DISTANCE**

3111 Old Lincoln Highway

Trevose, PA 19053-4996

Tel: 215-357-5500

Fax: 215-357-6216

E-mail: [info@GMPtools.com](mailto:info@GMPtools.com)

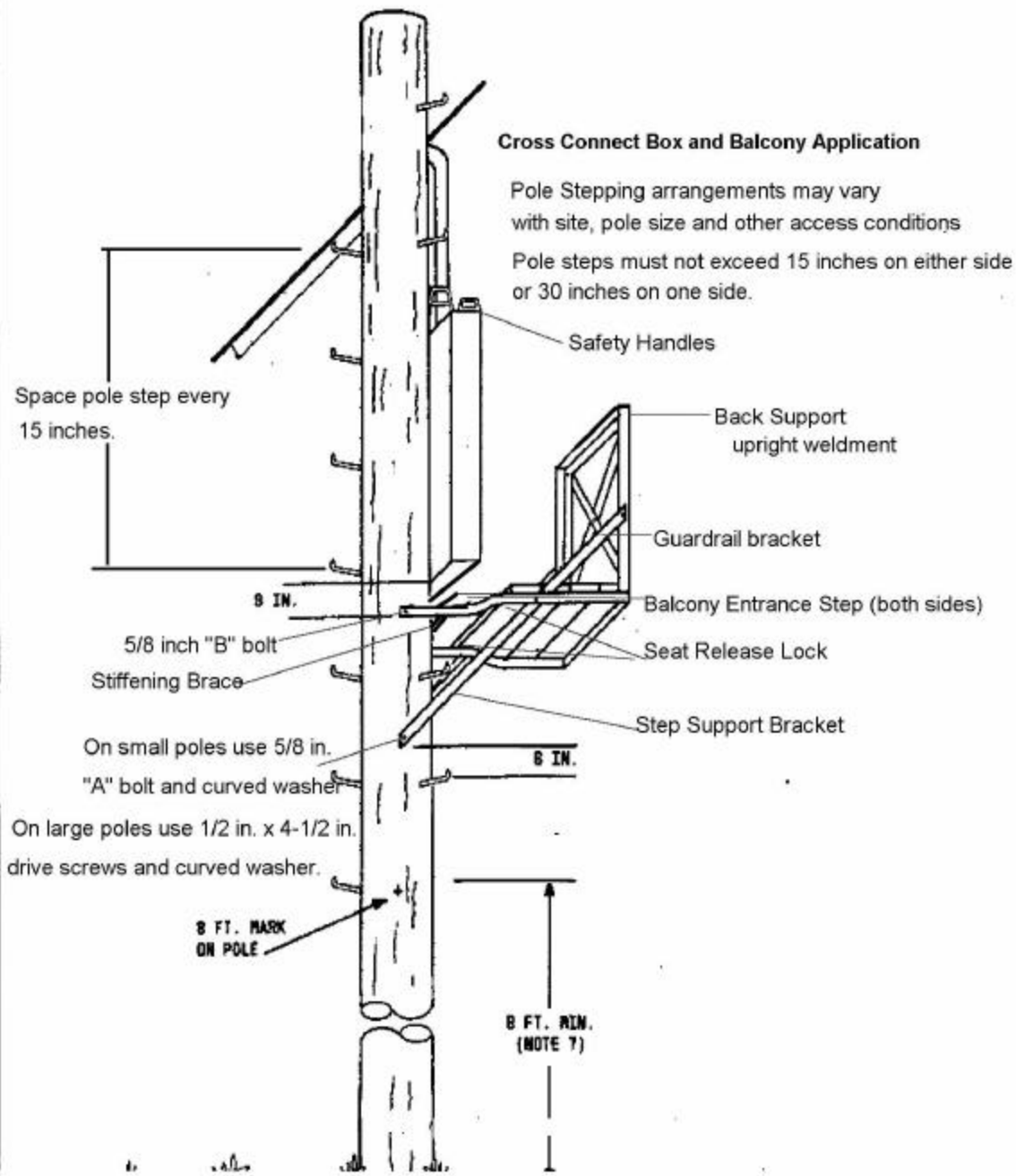

# STEP 1

## GMP 2000 CABINET BALCONY AS RECEIVED

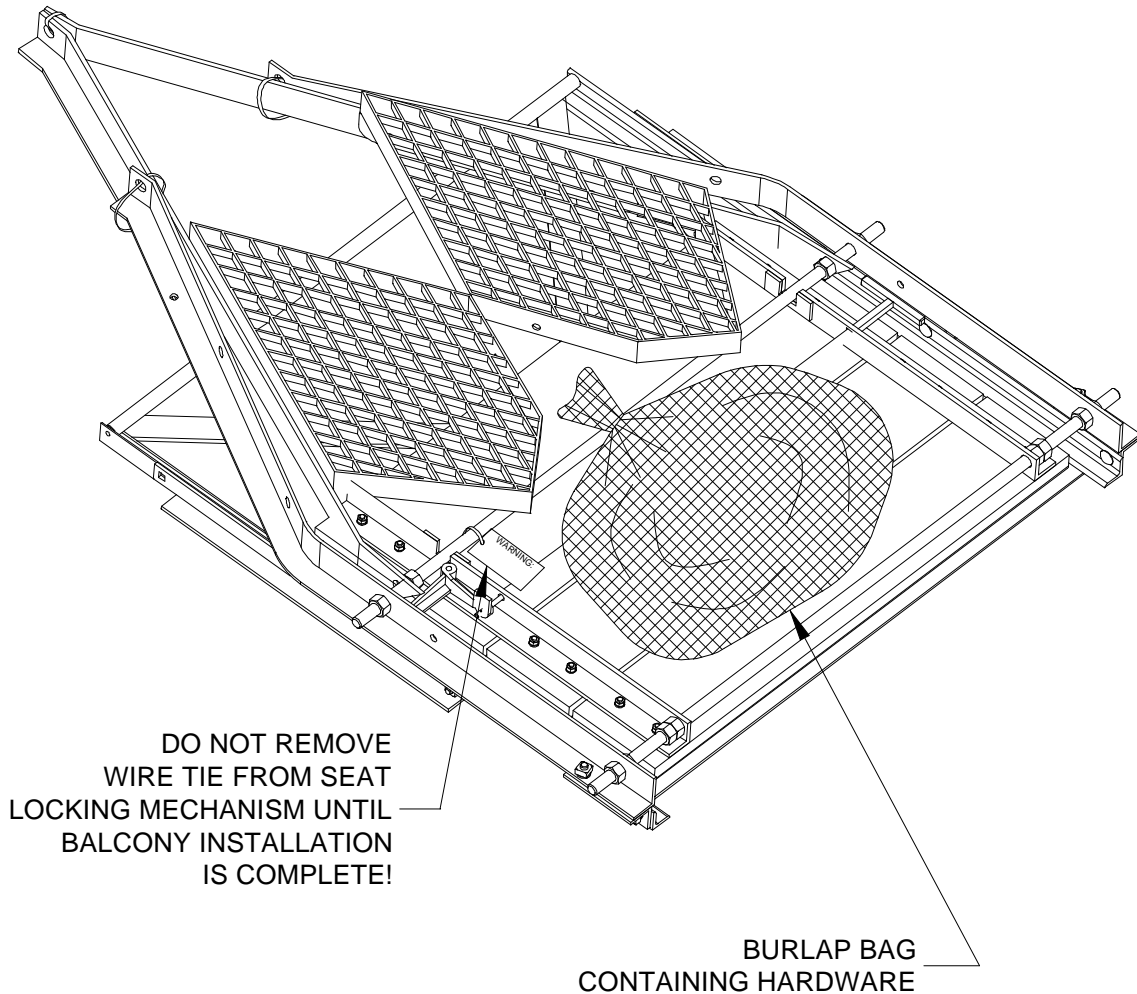

### WARNING:

1. IT IS IMPERATIVE TO TRANSPORT THE BALCONY, AS RECEIVED FROM THE MANUFACTURER AND NOT UNPACK IN ANY WAY, SINCE THE LOCKING DEVICE HARDWARE ALIGNMENT AND UNIT STRUCTURE ARE CRITICAL TO PROPER PLACING.
2. ONCE TRANSPORTED TO THE WORK LOCATION, REMOVE THE PACKING (EXCEPT FOR THE LOCKING MECHANISM TIE).

# STEP 2

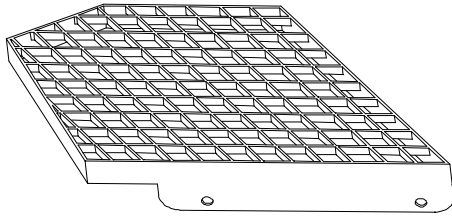

**A** ENTRANCE STEP L.H.  
QUANTITY = 1

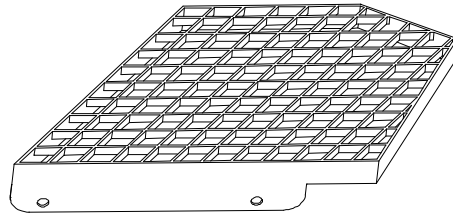

**B** ENTRANCE STEP R.H.  
QUANTITY = 1

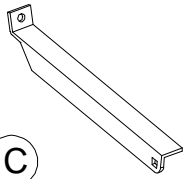

**C**  
ENTRANCE STEP  
BRACKET R.H.  
QUANTITY = 1

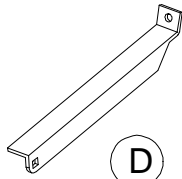

**D**  
ENTRANCE STEP  
BRACKET L.H.  
QUANTITY = 1

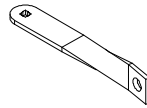

**E** POLE BRACE  
QUANTITY = 2

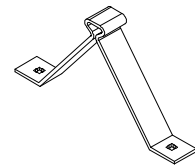

**F** STEP  
QUANTITY = 1



**1** 1/2-13 X 1.25 LG. SQ. BOLT  
QUANTITY = 4

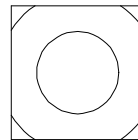

**2** 1/2-13 SQUARE NUT  
QUANTITY = 4

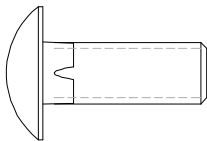

**3** 3/8-16 X 1" LG. CARRIAGE BOLT  
QUANTITY = 8

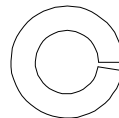

**4** 3/8 LOCK WASHER  
QUANTITY = 8

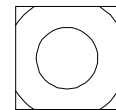

**5** 3/8-16 SQUARE NUT  
QUANTITY = 10

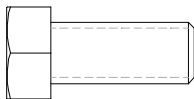

**6** 3/8-16 X 7/8" LG. HEX BOLT  
QUANTITY = 2

UNPACK THE CONTENTS OF THE BURLAP BAG AND LOCATE THE ABOVE PARTS.

# STEP 3

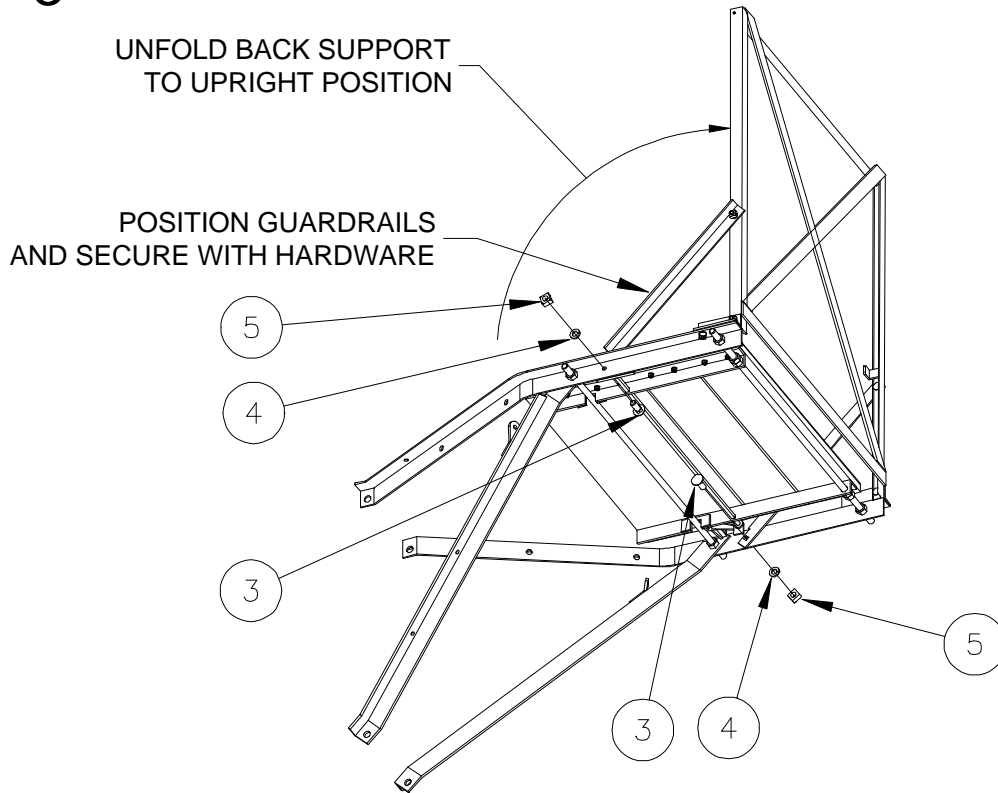

# STEP 4

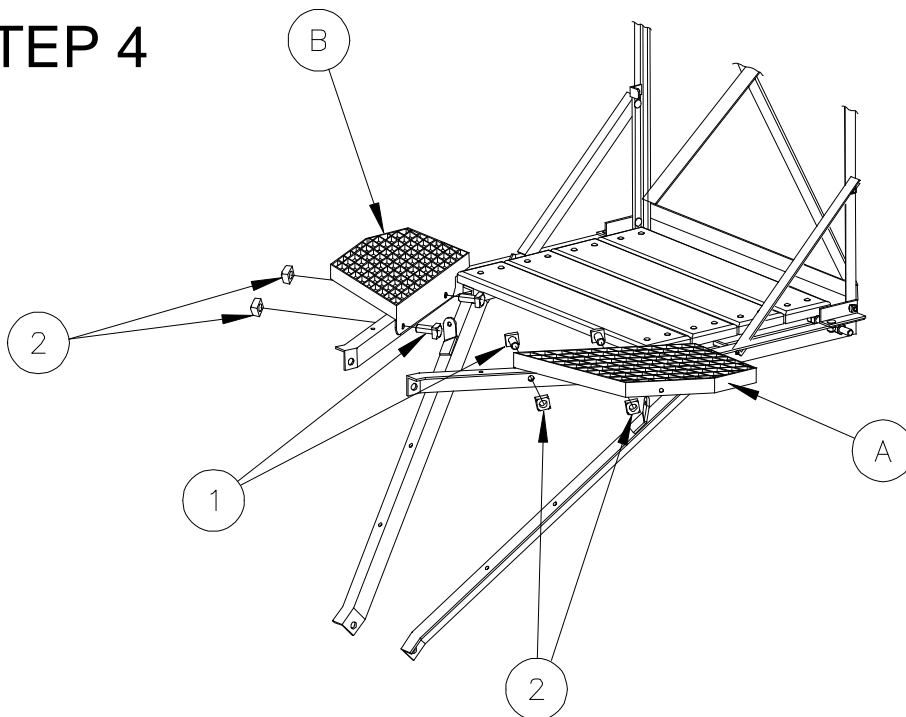

ASSEMBLE ENTRANCE STEPS, ITEMS A & B, TO BALCONY USING THE HARDWARE INDICATED AND HAND TIGHTEN.

## STEP 6

ATTACH THE STEP, ITEM F, TO THE SLOPED BRACE DETERMINED TO BE THE ENTRANCE SIDE OF THE BALCONY BASED ON LOCAL OR CORPORATE SAFETY PROCEDURES USING THE HARDWARE INDICATED AND HAND TIGHTEN.

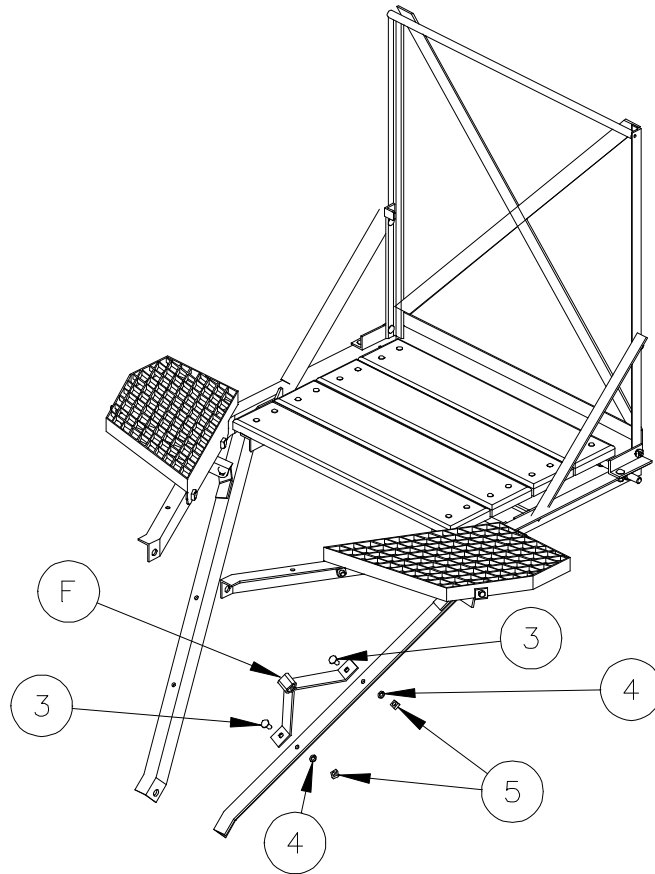

## STEP 7

RAISE THE BALCONY TO THE PROPER HEIGHT, ALIGNED WITH THE CROSS-CONNECT TERMINAL AND ATTACH THE BALCONY SUPPORT BRACKETS TO THE POLE USING APPROVED PROCEDURES AND HARDWARE ALLOWING 6 INCHES CLEARANCE BELOW THE BOTTOM EDGE OF THE CROSS-CONNECT TERMINAL AND THE BRACKETS.

POSITION THE BALCONY TO A LEVEL HORIZONTAL POSITION AND ATTACH THE BOTTOM SUPPORT BRACKETS TO THE POLE USING APPROVED PROCEDURES AND HARDWARE.

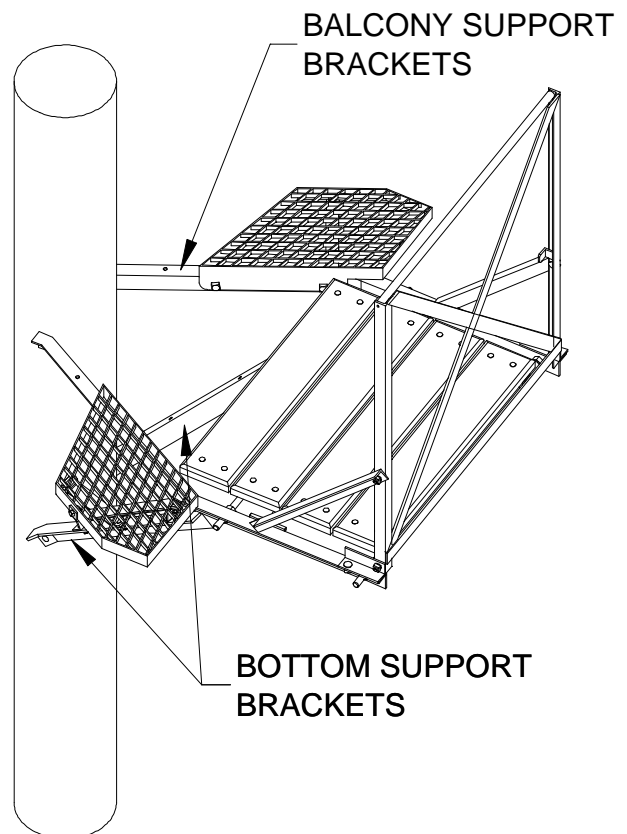

# STEP 5

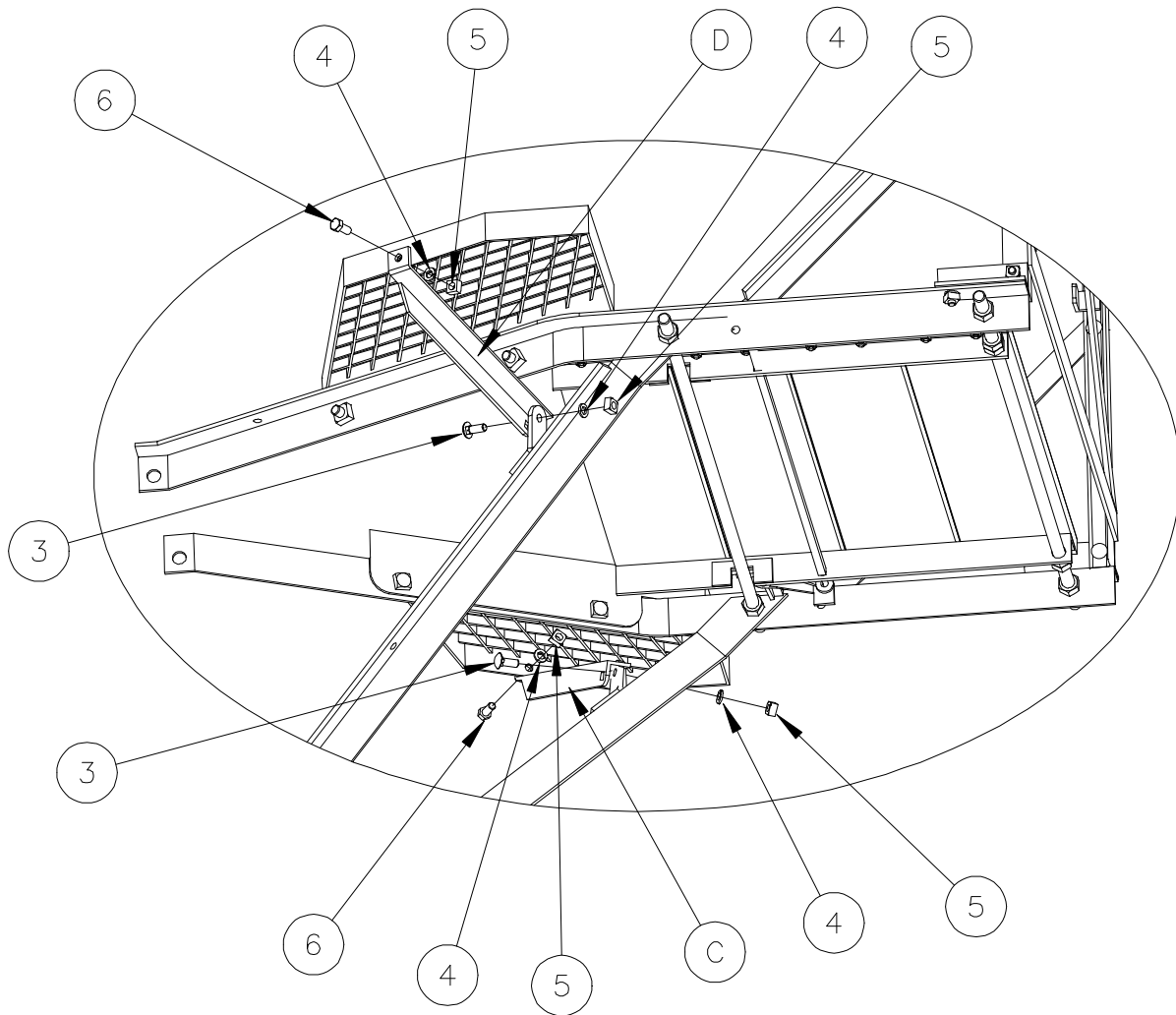

ATTACH THE ENTRANCE STEP BRACKETS, ITEMS C & D, TO THE BALCONY USING THE HARDWARE INDICATED AND HAND TIGHTEN.

# STEP 8

ATTACH THE POLE BRACES, ITEM E, TO THE BALCONY USING THE HARDWARE INDICATED AND HAND TIGHTEN.

ATTACH THE POLE BRACES TO THE POLE USING APPROVED PROCEDURES AND HARDWARE.

**IMPORTANT!** TIGHTEN ALL BOLTS.

REMOVE THE TIE HOLDING THE SEAT LOCKING MECHANISM.

ASSURE THE SEAT IS ABLE TO SECURELY LOCK WHEN RAISED TO THE STOWED POSITION.

