

TEMPORARY GROUNDING METHOD

Maintain good radio communications during a pull. Someone should follow and observe the winch line end and then the strand end during the pull while staying in radio contact.

It is important for the workers to wear insulating gloves in the case of hand pulling operations. Additionally, the worker should avoid other body contact to the line that is being pulled. As an additional precaution, a length of non-metallic hand line can be placed in between the worker and the line that he is pulling.

Reel tenders on the feed end of a hand pulling job should wear insulating gloves as well as stand on an insulating blanket.

No workers shall be permitted on the pole line during a pull.

Power companies have devices called reclosures in their circuits. These devices protect against temporary and incidental faults such as wind blowing phase wires together or into tree limbs etc. When a fault is

sensed, the circuit is opened for a brief moment and then automatically re-closes. It will stay closed if no further fault is sensed, however it will open again if there continues to be a fault. This sequence usually opens and closes three times before staying open in the case of an enduring fault. These power companies have the ability to turn off these reclosure devices very simply and remotely if they are made aware of the job. By turning off the reclosures, the power will cut out and stay dead after the first fault sensation. Supervisors planning these jobs should contact their power company equivalent and explore this extra safety precaution.

Maintain line of sight clearance to power conductors. Sometimes, the power conductors are drooped down below the imaginary straight line between the points of attachment of the new line. This is common in long span construction and could cause a hazardous situation when pulling at that level. In these cases, it may be necessary to pull the new line in at a lower point on the pole line. Once it is pulled in and properly tensioned, you can then raise the points of attachment up to the final position.

GENERAL MACHINE PRODUCTS CO., INC.
 3111 Old Lincoln Highway
 Treose, PA 19053-4996 USA
 Tel: 215.357.5500 • Fax: 215.357.6216
 Email: info@GMPtools.com
 Web: www.GMPtools.com

GMP reserves the right, without notice, to make changes in equipment design or components as progress in engineering or manufacturing methods may warrant.
 © 2002 General Machine Products Co., Inc.

Printed in USA GM 5732-0502



TOOLS BUILT TO GO THE DISTANCE



INSTRUCTIONS FOR USE



TEMPORARY GROUNDING METHODS AND THE EQUIPMENT USED

This describes temporary grounding procedures for grounding aerial lines being backpulled on joint leads from cable dollies or other equipment such as aerial plant placing bucket trucks. It also outlines procedures for temporary grounding of the winch lines used to pull the strand and/or cable in the same operations.

Temporary grounding is required in order to protect personnel while doing backpulling operations on de-energized lines. Temporary grounding is intended to protect against the following:

- (a) Induced voltage from adjacent energized lines
- (b) Fault current feed over from adjacent lines
- (c) Lightning strikes anywhere on the line
- (d) Accidental contact with adjacent energized lines such as flip-ups or shakedown

Equipment that is required to be grounded shall be, but not limited to, the following pieces of equipment:

- (a) Aerial plant placing aerial lift trucks with or without cable lashing machines when strand is back-pulled from the truck.
- (b) Aerial plant placing trucks that specialize in pre-lashing operations
- (c) Strand dollies where strand is being back-pulled.
- (d) All winch lines used for the same operations including non-metallic lines. Winch trucks; boom tip winches, rope reels and pulling trailers are examples.

NOTE: Non-metallic pulling lines are exempt if the pulling line manufacturer has certified its use as a valid dielectric pulling line.

Employees who undertake these back-pulling type jobs should be thoroughly familiar and trained on temporary grounding procedures and related safety issues.

SUITABLE PROTECTIVE GROUNDS*

Suitable grounding of lines being pulled in on a power exposed lead is necessary so that in case of exposure or contact, the power circuit will relay out.

Use the following grounds listed in order of priority:

- (a) A vertical ground connected to a multigrounded neutral or grounded neutral of a secondary system with three services connected.
- (b) Existing plant – strands and/or guys that are connected to:
 - (1) A central office ground
 - (2) An underground metallic piping system
 - (3) Power system neutrals as described in (a) above
- (c) Arrays of driven ground rods where resistance to ground is low enough to eliminate danger to personnel and permit prompt deactivation of power.

NOTE: An array of ground rods is more than one rod bonded together. Special measurements must be made in order to determine the effectiveness.

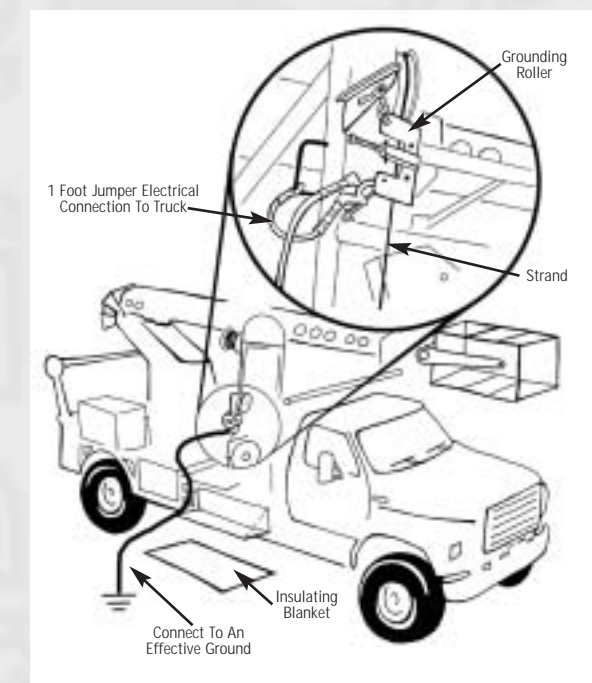

Figure 1 — Typical Telsta — Telelasher Ground Setup

*Occupational Safety & Health Administration Regulations (Standard-29 CFR) Telecommunications 1910.268 (m) (4)



TOOLS BUILT TO GO THE DISTANCE



TEMPORARY GROUNDING METHOD

GMP

TEMPORARY GROUNDING EQUIPMENT

Temporary grounding kits of adequate wire size are available. Each kit has:

- Temporary grounding roller for the strand or winch line to pass through.
- Fifty (50) foot jumper to bond the grounding rollers to the approved source of ground.
- One (1) foot jumper to bond the grounding roller to the aerial plant placing truck.
- Thirty (30) foot jumper provided for trailer bonding or adding extra length where needed

NOTE: Custom lengths available by special order.

Temporary ground cable is 1/0 AWG copper. This is capable of the following fault currents:

Cable Size	Fault Time Cycles	Amps
1/0 AWG	15	18,500
1/0 AWG	30	13,000
1/0 AWG	60	8,000

Based on 30° Centigrade (86° Fahrenheit) ambient and a total temperature of 175° Centigrade (347° Fahrenheit) for short circuit characteristic calculations for proper cables. Values are approximately 57% of fusing currents.

Standard cables are clear-jacketed poly-vinyl chloride (PVC). Clear jacket allows visual inspection of strand conditions of jumpers. (Black or yellow jacketed cables are also available.)

Each jumper end has been fitted with a crimped-on ferrule. A bronze body C-clamp is designed for easy and secure attachment to lugs, grounding bars, ground rods, grounded plant hardware and the buss bars on the grounding roller.

The grounding roller provides a means of maintaining a continuous ground connection to moving conductors such as strand or winch line being placed from a stationary reel. The roller must be connected to a low impedance ground as listed (see Suitable Protective Grounds section) to minimize the voltage which will be impressed on the conductor in the event of an accidental contact with an energized power conductor.

The three rollers on the temporary ground contact bronze bushings, which maintain continuous contact to the frame. The middle roller is spring tensioned. Both ends of the frame have hold back holes. Both ends of the frame have buss bars for attaching the bronze body C-clamp.

INSTALLING TEMPORARY GROUNDS

Locate suitable low impedance ground. Try to plan job according to one of the approved ground locations outlined in the Suitable Protective Grounds section.

NOTE: Temporary grounding procedures apply to both the feed end and pulling ends of the job on a joint lead.

Bond the truck or dolly to the grounding roller. This is accomplished with the one foot jumper on the plant-placing machine.

NOTE: Some equipment may require retrofitting a suitable grounding attachment, lug, et. in a convenient location.

Uncoil and attach one end of the fifty foot jumper cable to the source of ground. Attach the other end to one of the buss bars on the grounding roller.

Place the adjustable spring tensioned grounding roller onto the strand on the feed end of the job and onto the winch line on the pull end of the job. The grounding roller may require being tied back by using one of the holes provided in the body of the device.

Remember – Both ends of the job should be treated the same with respect to temporary grounding.

Once the pulling operation is completed and permanently tensioned, the grounding equipment can be removed. Remove the grounding equipment starting with the traveling grounds. Then coil up the jumper cables and store the components out of the elements

OTHER RELATED SAFETY ISSUES

In an accidental power contact, fault current voltage will seek every ground available. In that instant, the current will not only travel to the ground through your grounding set but also to people who happen to be touching the equipment. Therefore, it is very important to keep other workers and pedestrians away from the equipment during the pulling operation. Use barricades, cones or rope off the area as appropriate.

Place an insulating blanket out as part of the set-up prior to the job. The blanket should be placed on the ground where the employee would exit the console area if the need arises. Insulating gloves should also be close and available to these operators.

Winch truck operators, pulling trailer operators, strand dolly tenders, and reel tenders standing on the ground should work while standing on an insulating blanket and wear insulating gloves.

Keep proper brake tensions on strand and winch lines to insure a smooth Pulling operation. Avoid surges. It is generally not acceptable to use polypropylene or nylon lines as winch lines because they tend to stretch and can cause hazardous surging.

(Continued on back page)

TYPICAL GROUNDING SETUP ILLUSTRATIONS

NOTE: Operators should use insulating equipment (glove and blanket) where appropriate

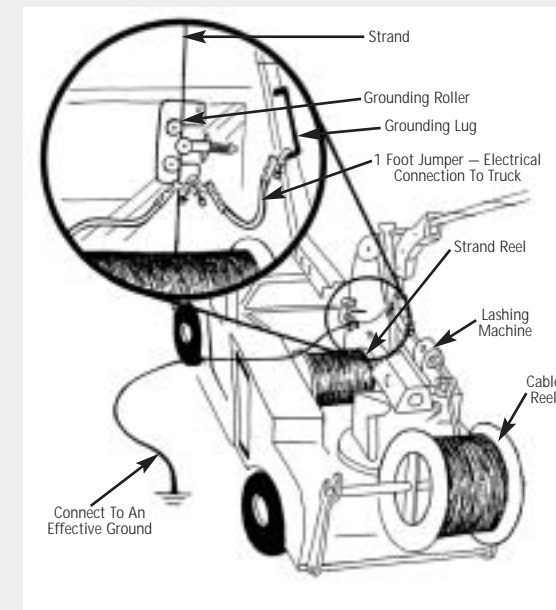

Figure 2 – Typical Telsta – T40C (or similar) setup

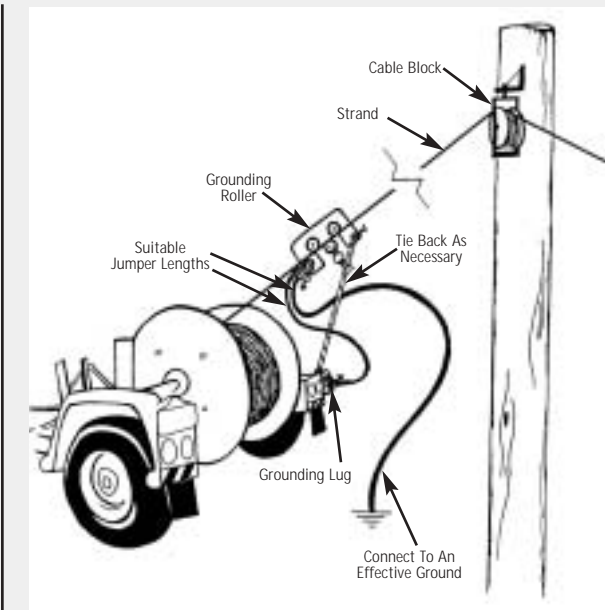

Figure 3 – Typical strand dolly grounding

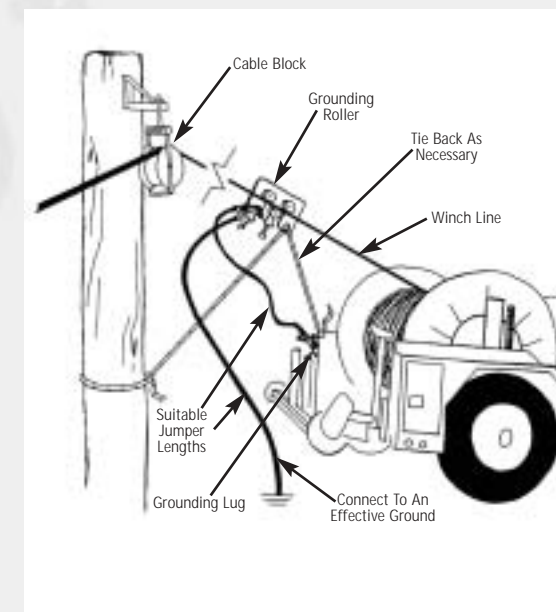

Figure 4 – Typical pulling trailer setup

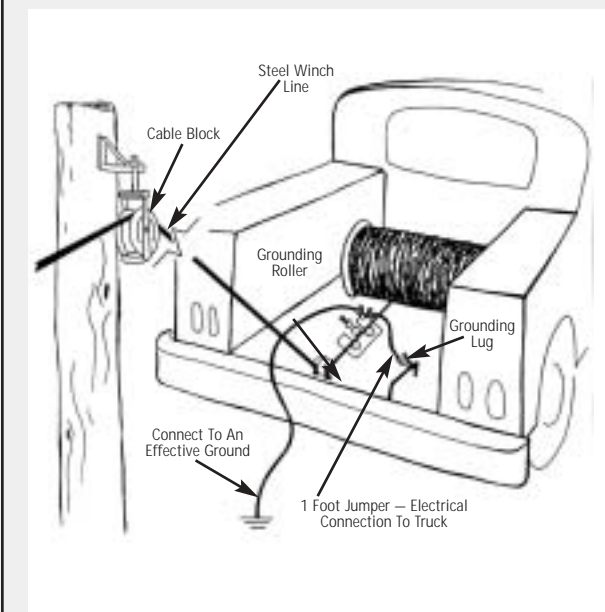

Figure 5 – Typical winch truck setup