



# BREEZE MICRO CABLE BLOWING MACHINE

## OPERATION & MAINTENANCE



### 89010 (BREEZE) – USA CABLE BLOWING MACHINE

Copyright 2009 by General Machine Products Co., Inc

QC Final Inspection by: \_\_\_\_\_ Date: \_\_\_\_\_

Unit Serial Number: \_\_\_\_\_

Build Date: \_\_\_\_\_

All rights reserved. No part of this publication may be copied, reproduced or transmitted in any form whatsoever without the written permission of General Machine Products Co., Inc.



GMP • 3111 Old Lincoln Hwy • Trevose, PA 19053 • USA  
TEL: +1-215-357-5500 • FAX: +1-215-357-6216 • EMAIL: info@gmptools.com

March 29 2011 USA Ver 7

Manual Part Number 32384

## REVISION HISTORY

<b>Rel.no</b>	<b>Date</b>	<b>Details</b>	<b>Author</b>
01	08.27.03	Original issue	A. Sibun
02	09.19.07	US Version 1	A. Kenschak
03	07.05.07	US Version 2	A. Kenschak
04	04.30.08	US Version 3	A. Kenschak
05	05.25.09	US Version 4	A. Kenschak
06	11.23.09	US Version 5 - updated CUB5 Matrix	A Kenschak
07	06.09.10	US Version 6 - update Appendix 1	A Kenschak
08	03.29.11	US Version 7 - update blown fiber page 24	A Kenschak
09	05.18.11	US Version 8 - add guide positioning warning	A Kenschak

## **CONTENTS**

1. Safety Instructions
2. Critical Points
3. General Description
4. Specification
5. Operating procedures
6. Maintenance
7. Procedure for changing inserts in the tube clamp
8. Procedure for changing inserts in the air box
9. Procedure for changing inserts in the infeed guide
10. Procedure for re-positioning the measuring system fixed roller
11. Procedure for replacing the air box housing seal
12. Procedure for changing the air box infeed guide
13. Procedure for changing the drive rollers
14. Procedure for conversion to blow 12 count (1.6) fiber
15. Monthly Service – check list
16. Service History Record
17. Tube integrity and Lubrication
18. Recommended Spares List

## **APPENDICES**

- |                   |  |
|-------------------|--|
| <b>Appendix 1</b> | <b>Cable and tube insert selection chart.</b>            |
| <b>Appendix 2</b> | <b>Recommended torque control potentiometer settings</b> |
| <b>Appendix 3</b> | <b>Programming the speed/distance measuring device.</b>  |

### **GMP Limited Warranty**

# 1. SAFETY INSTRUCTIONS

**This Equipment should be used only by personnel who have been given the appropriate training and who are competent to use it. These instructions are to be made available to operators of this equipment at all times. Failure to observe these safety instructions could result in serious personal injury and/or property damage.**

## WORK AREA AND GENERAL SAFETY

1. Read and understand the operation and maintenance manual supplied with this equipment. Keep it in a convenient place for future reference.
2. Keep children and untrained personnel away from this equipment while in operation.
3. Keep all guards and safety devices in place. Do not operate this equipment with guards removed or damaged.
4. Keep hands, feet and loose clothing away from moving parts, especially at cable entry points.
5. Always stop the machine and isolate compressed air and electrical services to carry out lubrication and servicing.
6. Check machine before starting for worn or damaged parts. Check for signs of loose nuts and bolts etc.
7. If machine is left unattended, insure that unauthorized use is prevented.
8. Never leave the machine unattended while in use.
9. Consider the use of safety barriers, especially when used in public places, observe all statutory requirements for working environments.
10. Beware of pinch points involved with rotating components.
11. Beware of hot surfaces, machine uses compressed air.
12. When operating machine always wear appropriate safety clothing, hearing protection, eye protection, hard hat, safety shoes and leather gloves, machine operates with compressed air at up to 218 psi.
13. Prior to installation insure the tube route is connected properly.
14. Beware of exposed electrical contacts. Do not touch, or allow metal objects to come into contact.
15. Machine may cause additional fire hazard if involved in an existing fire due to compressed air.

16. No personnel are to be in manholes or ducts when the Cable Blowing Machine is being operated.
17. The machine must be operated on firm ground.
18. Stay clear of cables or lines under tension.
19. Stay clear of pressurized air line and tube.
20. Only use the machine for its intended purpose. Do not use the roller drive without the air chamber to push or to retrieve cable or blow air in the far end of tube to help cable recovery.
21. Do not place cable drum too close to the Cable Blowing Machine.
22. Do not tamper with pressure relief valves or pressure reducing valves.
23. The compressed air supply must not be allowed to enter the air chamber or tube before the drive rollers have been closed on to the cable. Do not turn the air on until a reasonable length of cable (165 ft) has been installed into the tube.
24. Ensure the cable drum rotates freely on its stand, the cable should leave from the top of the drum.
25. The cable should enter the machine in a clean and dry condition. In damp, dusty atmospheres, the cable should be cleaned continuously as it enters the machine.

**FAILURE TO DO SO MAY RESULT IN PERSONAL INJURY, AS THE CABLE  
COULD BE EJECTED FROM THE CABLE BLOWING MACHINE WITH HIGH  
FORCE AND VELOCITY.**

## **GENERAL PNEUMATIC SAFETY INSTRUCTIONS**

The CBS Fiber Optical Cable Blowing Machine is a pneumatic device, using pressurized air to project cable at high velocities. Please observe the following precautions when operating the Cable Blowing Machine:

1. Compressed air can cause flying debris. This could cause personal injury. Always wear personal protective equipment.
2. Insure no personnel are in the manhole at the far end of the cable run. Severe personal injury may result.
3. Never open the air chamber when pressurized.
4. Only authorized, fully trained personnel should operate the air compressor.

## **GENERAL ELECTRICAL SAFETY INSTRUCTIONS**

The machine has electronic and electrical power and control circuits. Electric shock hazards exist that could result in severe personal injury. Observe the following precautions to avoid electrical hazards:

1. Do not operate in water.
2. Do not expose the machine to rain.
3. Do not remove cover of electronic control assembly. There are no user serviceable parts inside.
4. Refer servicing to qualified service personnel.

## **2. Critical points that dramatically affect the operation of the cable blowing machine.**

- a. Pressure on the cable (Position of the close arm assy) should be set as per the instructions.
- b. Rollers to be closed at all times when cable is installed into machine.
- c. Cord seals in air chamber correctly fitted to provide good sealing.
- d. Correct cable seal fitted.
- e. Tube fully connected and pressure-tested.
- f. Tube connecting fittings are suitable for operating at 218 PSI air pressure.
- g. Tube clamp securely tightened.
- h. Compressor capacity 218 PSI and suitable for size of tube being used.
- i. Cable drum must be located directly behind and in line with the blowing machine.
- j. Air chamber, drive rollers, cable guides, must be clean and free from debris, sludge, dirt, water and lubricant.
- k. The cable must be hand guided into the blowing machine through a dry clean cloth by the operator wearing work gloves.
- l. Ensure the compressed air supply is not applied to the cable until approximately 165 ft of cable have been installed or the motor begins to labor.

## **DISCLAIMER**

General Machine Products Co., Inc and CBS Products Ltd. takes care in the design of its products to insure that the cable is protected during installation. Due to the variety and different methods of cable manufacture the responsibility of checking the cable compatibility with the equipment lies with the user. Therefore, GMP nor CBS Products Ltd. can accept liability for any damage to the cable.

### 3. GENERAL DESCRIPTION

The CBS Breeze Micro Cable Blowing Machine is designed to install small diameter cable into micro tubes.

The Breeze uses a DC motor and reduction gearing to drive a pair of compliant rollers (both rollers are driven).

The rollers are covered with a soft synthetic coating to prevent damage to the cable. Different coatings are available depending on the surface texture of the cable being installed. The rollers may be changed quickly using one simple tool.

The pressure the rollers apply to the cable may be set between zero and maximum. During installation, the torque applied to the cable by the rollers can be adjusted to prevent the cable buckling and damage to the cable.

A full range of accessories are available to allow the machine to handle a wide range of cables and tubes.



As pictured above, the Breeze may be placed on the ground or on a support to bring the cable to a suitable height. The Breeze is supplied with a reinforced case which will protect the machine from damage during transit and can also be used as a support for the machine when installing cable.

## 4. SPECIFICATIONS

<b>Cable size:</b>	2.5 to 8.0 mm <sup>1</sup>	0.1" to 0.315"
<b>Tube size: (OD)</b>	5 to 16 mm	0.197" to 0.629"
<b>Cable speed:</b>	0-50m/min.	0-165 ft/min
<b>Maximum pushing force:</b>	16 Kg.	35 lbs.
<b>Maximum air pressure:</b>	15 bar.	218 psi.
<b>Power requirements:</b>	115/220V ac 50/60 Hz Switchable	
<b>Gripping force, (rollers onto cable):</b>	1-40 Kg	1-88 lb.
<b>Weight</b>	23Kg approx.	50 lbs. approx.
<b>Dimensions (ht x length x width)</b>	250mm x 390mm x 270mm	10" x 15 3/8" x 10 5/8"

<sup>1</sup> 1 - 2.5 mm blown fiber available with add-on kit

## 5. OPERATING PROCEDURE

IT IS IMPERATIVE THAT ALL PERSONS USING, OPERATING OR MAINTAINING THIS CABLE BLOWING MACHINE:

- HAVE RECEIVED COMPREHENSIVE TRAINING IN THE USE OF THIS MACHINE.
- ARE COMPETENT AND AUTHORIZED TO USE IT AND HAVE READ AND UNDERSTAND THIS MANUAL.

GENERAL MACHINE PRODUCTS CO., INC OR CBS PRODUCTS LTD. CANNOT BE HELD RESPONSIBLE FOR MISUSE OF THIS EQUIPMENT.

**Set up for installing cable with the machine mounted above ground:**

- a. Position the machine in line with the route of the duct.
- b. Position the cable drum behind the machine and in line with the machine.  
See sketch below (this shows a plan view of the recommended set up).

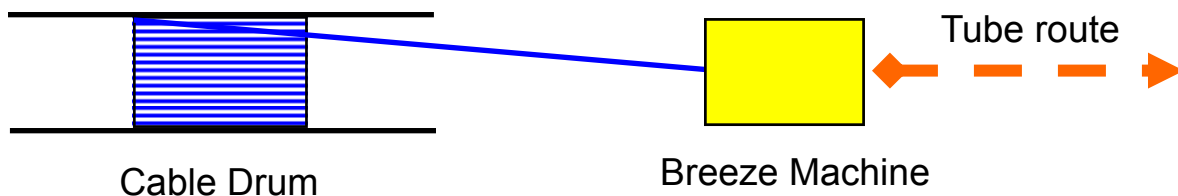

- c. Ensure the machine is secure (either on its own stand or a separate suitable stand).
- d. Ensure the machine is fitted with the appropriate guides and collets to suit the cable being installed and the tubes into which the cable is to be installed. (See appendix 1 for details of interchangeable parts).

**To set the machine up to install cable it will be necessary to:**

1. Fit the tube into which the cable is to be installed into the tube clamp and air box .
2. Fit the cable through the machine.
3. Connect the air supply to the machine.
4. Connect the electrical power input to the machine.

## Fit the tube into which the cable is to be installed into the air box and tube clamp.

Slide a tube seal, sized for the tubing you are using, over the end of the tube.

Fit the tube about half way into the air box housing as shown in the photo, positioning the tube seal so that it sits against the seal face.

Positioning the tube further into the air box helps prevent the bucking of smaller fiber.

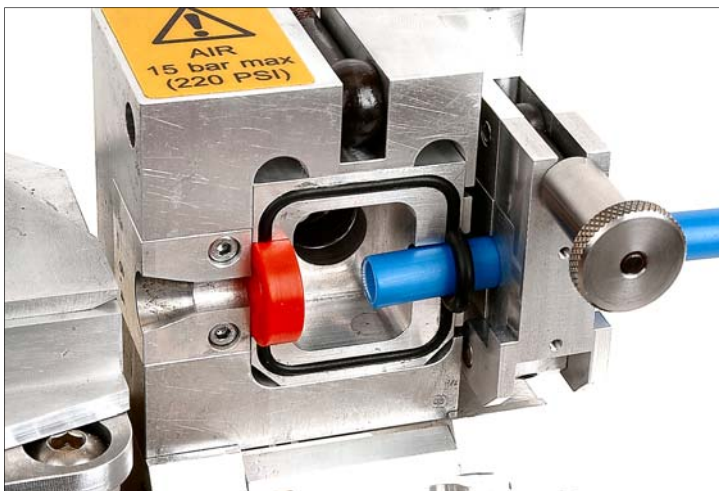
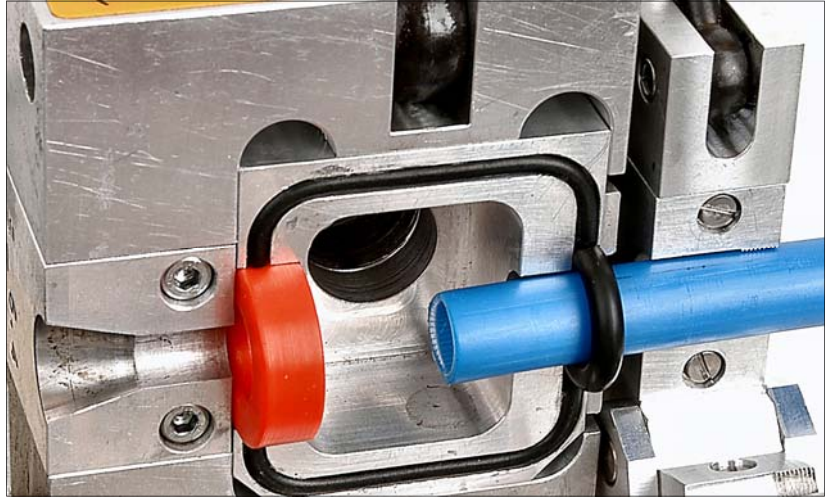

Once the tube has been positioned, the tube clamp may be closed. With the swing bolt swung down and the thumb nut tightened. The tube is now secure.

Cut and split a short length of tube to use as an in-feed guide (this tube need only be split if blowing a cable mid-span; sometimes called series blowing). This should be inserted in the in-feed guide clamp. (In order to give the best support for the incoming cable, it may be helpful if the end of the tube is cut off at an angle to match the angle on the in-feed guide clamp. This short length of tube will act as a guide to feed the incoming cable into the measuring system and into the in-feed guide. If necessary a length of smaller diameter tube may be fitted inside this tube to act as a guide for smaller diameter cables.



## Fit the cable through the machine.

Raise the clear cover to expose the roller drive.

Loosen the thumb nuts and retract the cable guide top plate.

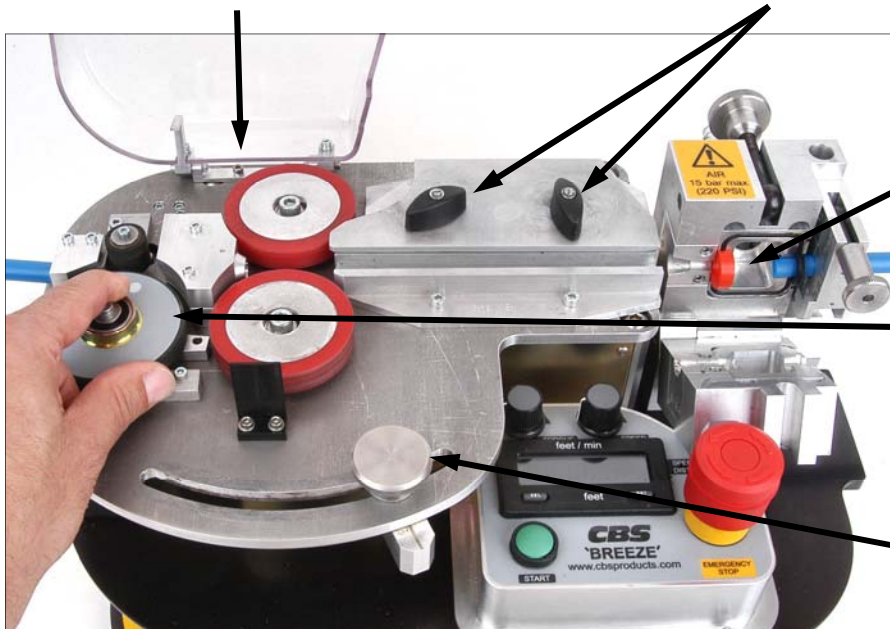

Loosen the thumb nut and open the seal housing.

Hold back the measuring wheel, so that the pressure spring is compressed.

Move the drive roller close assembly to the far right to fully open the rollers.

It is now possible to insert the cable in the machine.

Pass the cable through the tube in the in-feed guide clamp, on through the in-feed guide assembly and through the gap between the drive rollers. Place the cable in the groove in the cable guide assembly (out-feed). Select the appropriate split cable seal (see appendix 1) and position it around the cable. Press the cable seal into the groove in the seal housing, simultaneously placing the cable in the cable seal guide and inserting the cable in the tube entry.

The cable is now positioned in the machine.

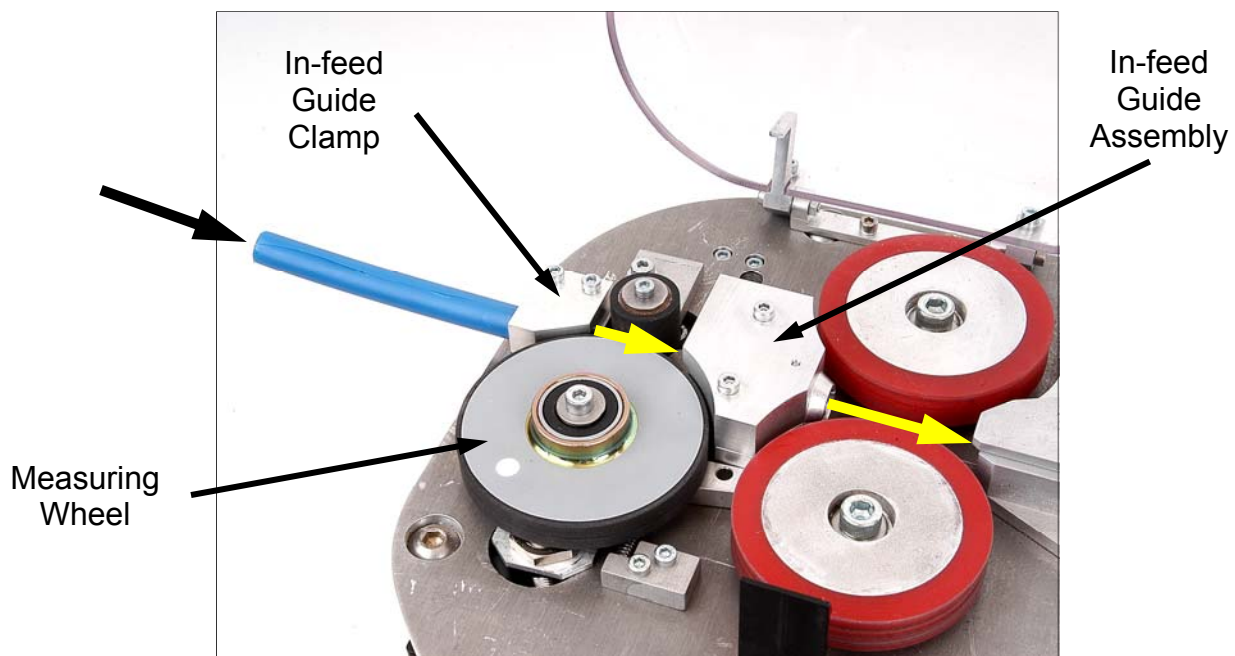

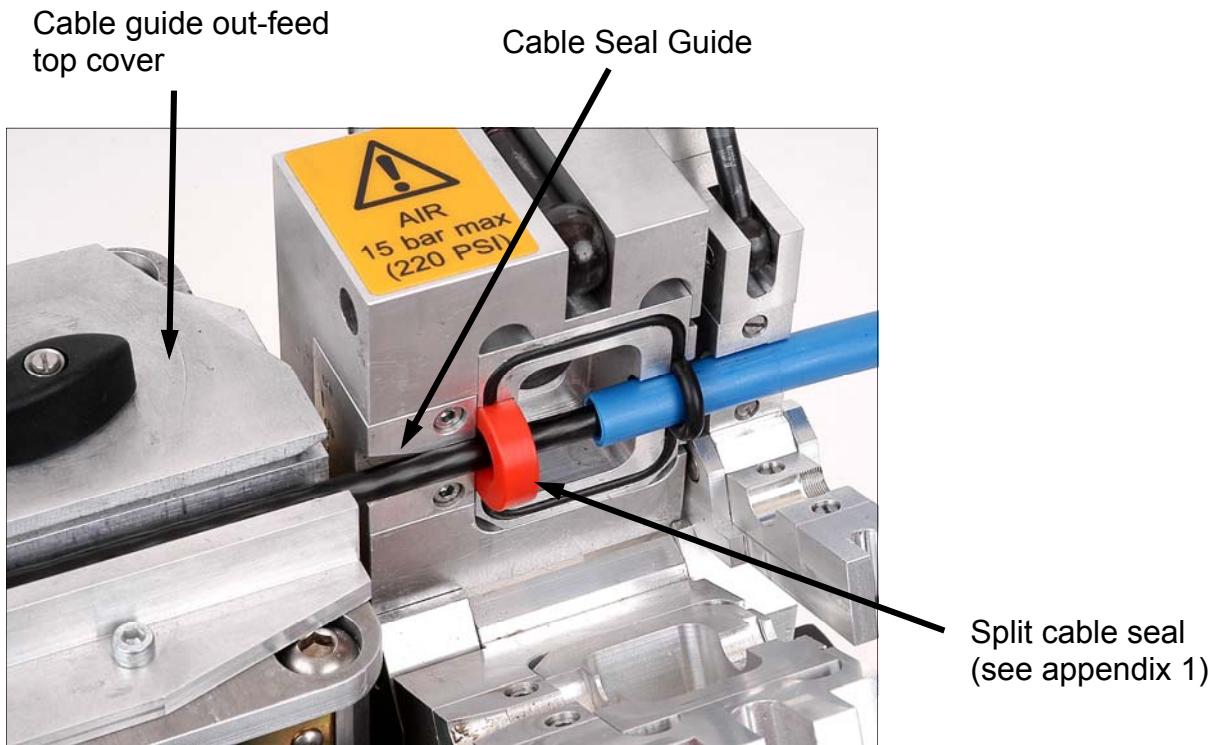

- a. Close the air box.
- b. Close the cable guide out-feed top cover.
- c. Release the measuring wheel and allow it to rest on the cable.
- d. Close the transparent cover over the feed rollers. (**note:** This cover must be closed in order for the machine to operate)

Close the drive roller assembly onto the cable as follows:

The photo shows the drive roller close thumb nut slightly loosened. (The assembly is free to move).

This thumb nut is fixed to the clamp arm lever. The clamp arm lever controls the position of the roller assembly.

As the clamp arm is moved to the left, the rollers move together. When the clamp arm is furthest to the right, the gap between the rollers is at its widest. Once the cable has been positioned in the machine the rollers must be closed on the cable in order to drive the cable. (And to stop the cable being dragged back out of the machine by any tension in the cable).



The amount of pressure on the cable can be varied simply by loosening the thumb nut, moving the clamp arm lever to the right or left; as required, and tightening the thumb nut. As more experience is gained using the machine, the amount of compression required will become clear. **Note:** An alternative method of setting the compression force is detailed in the note at the end of appendix 2.

### Connect the air supply to the machine.



The air inlet to the machine is male fitting for a quick release coupling.

Supplied with the Breeze is a reinforced braided supply line with a 300 psi pressure gauge, ball type shut off valve and a quick disconnect female coupling for connecting to the machine. A 1/2"



twist-lock claw hose coupling is provided to connect to your compressor.

### Connect the electrical supply to the machine.

The Breeze is designed to operate with either 115 volts or 220 volts AC. The default setting in the America's is 115 volts. To change the voltage setting, locate the voltage switch under the silver plug located to the left of the fuses. Looking into the hole with a flashlight, position the switch to the desired voltage.

The machine is supplied complete with an electrical supply lead. Fit a suitable adaptor to the free end of the lead and connect to power supply.

If the connecting plug on the power lead to the generator/ (or supply) supplied with the Breeze machine is unsuitable and requires replacement, the new plug must be correctly connected observing the color codes as shown below.

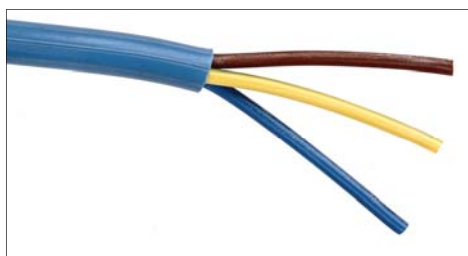

Brown (Live)

Yellow & Green  
(Earth)

Blue (Neutral)

It is the responsibility of the user to ensure that the connections meet the electrical regulations for the relevant country.

The machine is now ready to start the cable installation.

**Set up for installing cable with the machine mounted below ground:**

The set up is similar to the set up for installing cable above ground, (described above) typically this type of installation is demanded for “series blowing” i.e. when a length of cable is already installed, and the limit of installation distance is reached. In such cases it is customary to couple a “series machine” sited down a manhole some distance from the point of main installation. This machine operates in conjunction with the machine sited at the main point of installation. The CBS Breeze machine is ideally suited to this type of operation, it may be coupled with a second machine to increase the distance a single cable can be installed without joins. The only difference between this set up, and the set up for installing cable with the machine above ground, is that there will be no drum stand carrying the cable drum. The cable will be exiting from one side of the manhole and blown into the tube at the other side of the manhole. The machine should be aligned with both the incoming cable and the outgoing tube path, both side to side and up and down.

**NOTE: THE MACHINE MUST NOT BE SUBMERGED IN WATER.**

If the hole is full of water it must be pumped out before placing the machine on the bottom of the hole.

## Installing cable.

The machine is fitted with a range of controls to help the operator to install cable in the minimum time with the least risk of causing damage to the cable or tube.

These controls are identified and their function is described below.

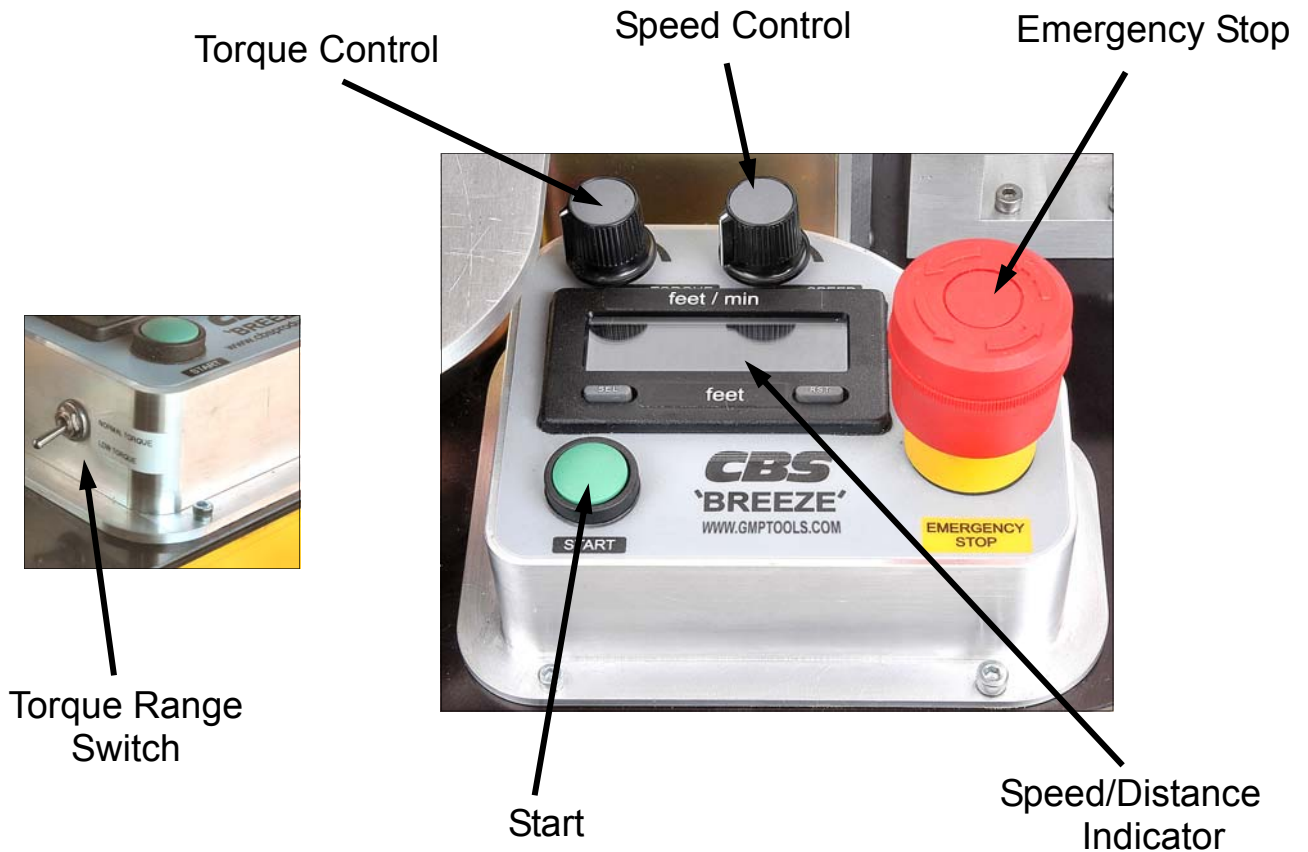

### Torque control:

This knob controls the motor torque, turn this clockwise to increase the torque (pushing force) applied to the cable by the rollers. Turn counter clockwise to reduce the amount of torque (pushing force) applied to the cable by the rollers.

### Torque Range Switch:

Switches between “normal” torque range for blowing micro fiber cables and “low” torque range for finer torque adjustment when installing 1-1.6 mm “blown fiber”.

### Speed control:

This knob controls the motor speed, turn this clockwise to increase the speed of the rollers (and the cable). Turn counter clockwise to reduce the speed.

### Emergency stop:

Pushing this red knob downwards will stop the rollers feeding the cable. This knob may be used to switch the machine off, whether or not there is a need to stop in an emergency. To release, twist the red knob counter-clockwise.

## Start:

This switch “arms” the emergency stop circuit. If the emergency stop button is used to stop the machine (whether in an emergency or not) it will be necessary to depress this switch before the machine will run again. Whenever the power to the machine is disconnected and re-connected, it will be necessary to depress this switch before the machine will run.

## Speed Distance indicator:

This device will measure and display the distance traveled by the cable and also the speed at which the cable is traveling. The functions are controlled by the small push button on the right of the display. If this button is depressed, the display will “toggle” between speed and distance. If held down for more than three seconds, the display will reset to zero. Before starting an installation, it will be necessary to depress the button for more than three seconds to set the distance display to zero. Should it be necessary to replace the speed distance measuring indicator, it will be necessary to reprogram it. See appendix 3

## To install cable:

For the **first time** installing a cable type that has not been installed before and whose characteristics are unknown.

1. Connect the power to the machine. The power supply should be nominally 115 volts single phase ac 50 or 60 Hz. This may be derived from an IC engine driven generator, domestic or industrial electrical supply, rotary converter or similar. The power source should be fitted with a suitable connector, see “Connect the electrical supply to the machine”. Page 15 of this manual.
2. Turn the torque control knob left, to the maximum counter clockwise position.
3. Turn the speed control knob to a position midway (11:00) between the maximum counter clockwise and maximum clockwise position.
4. Press “start” button.

The machine will try to push the cable, with the torque control set to a minimum the rollers will not turn or only very slowly.

It is now necessary to set the torque control to a position appropriate to the stiffness of the cable and the characteristics of the cable insulation. See appendix 2 for recommendations. If the cable type has been installed before, the settings will be available, the torque control knob may be set at the previously determined position.

Set the torque control knob to the position determined above. The rollers will now start to turn, and the cable will feed through the air box. When the cable has traveled a reasonable distance, (say 165 feet) turn on the air feed, this will help the machine to feed the cable.

The tube route through which the cable is to be fed, should be configured in such a way that the cable can feed all the way along the tube and out the other end. It will be necessary to be able to determine when the cable has emerged at the other end of the tube route. A typical way of achieving this aim is to have a colleague positioned at the end of the tube run, in contact with the main installer using a radio. In this way the main installer will be advised when the cable has completed the run, so he can then stop the machine.

If there is an unexpected obstruction in the tube route, the rollers will see this as an increase in torque demand, assuming the torque control has been set at an appropriate level. The rollers will stop turning before they push the cable so hard as to cause it to buckle. If (due to lack of previous knowledge of the cable characteristics) the torque control has been set at a figure which is too small to push the cable, the setting may be increased. Bear in mind that this will increase the risk of the cable being damaged by buckling.

## 6. Maintenance

The CBS Cable Blowing Machine has been designed to give reliable, trouble free service over long periods. The machine requires no sophisticated maintenance procedures, simple common sense checks and precautions are all that are needed.

The main source of breakdown and/or malfunction of a machine being used outdoors is contamination by the elements, this contamination may be introduced into the machine in a number of different ways.

There may be mud, dust or other contaminants carried into the machine on the cable or tube (there may be surface coatings of lubricants or other release type agents on the outer surfaces of the cable and tube, this could build up on the rollers and make them slip).

The machine may be set down on a muddy surface, or be splashed by road going vehicles when it is being used by the roadside.

**Measuring system fixed roller:** this should be kept clean. Build up of dirt etc on the faces will cause faulty readings of speed and/or distance. Clean with warm soapy water, wash off and allow to dry. For stubborn marks and build up M.E.K\* may be used.

### In-feed Guide

**Clamp:** this should be kept clean. Build up of dirt etc on the faces will cause the cable to catch on the guide. Clean with any workshop solvent.

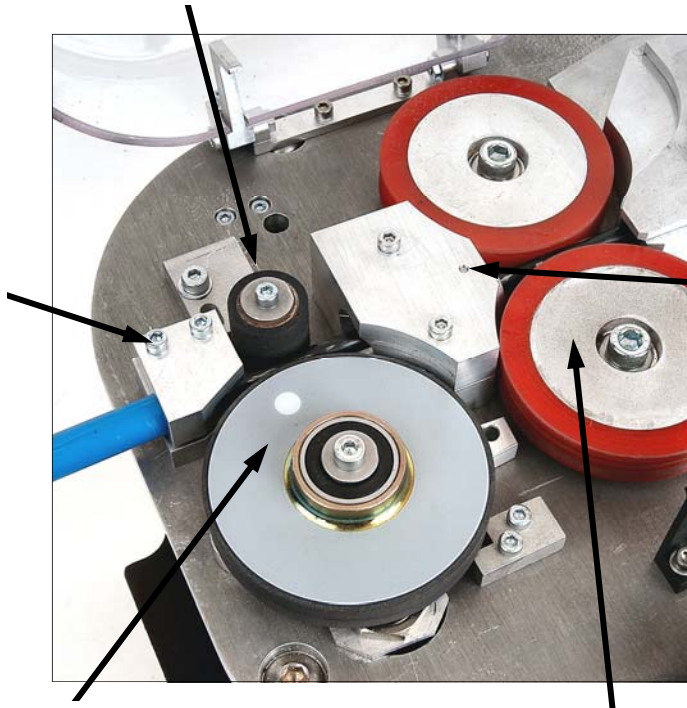

### Infeed guide assy:

this should be kept clean. Build up of dirt etc on the faces will cause the cable to catch on the guide. Clean with any workshop solvent. Pay particular attention to the joint faces of the inserts and the housing.

**Measuring roller:** this should be kept clean. Build up of dirt etc on the faces will cause faulty readings of speed and/or distance. Clean with warm soapy water, wash off and allow to dry. For stubborn marks and build up M.E.K\* may be used.

**Drive rollers:** these should be kept clean. Build up of dirt etc on the faces will cause slip and/or jerky feeding of the cable. Clean with warm soapy water, wash off and allow to dry. For stubborn marks and build up M.E.K\* may be used.

\* M.E.K. (methyl ethyl ketone) is a solvent; the safety precautions outlined on the document supplied with the chemical **must** be observed.

**Cable guide parts:** Keep clean. A build up of moisture and dust may nip the cable. This could cause the machine to stop feeding. Loosen the thumb nuts and slide back the top plate to expose the guide groove. Use any traditional workshop cleaning agent.

**Air box parts:** Keep clean. A build up of moisture and dust will prevent the joint faces from mating, preventing the housing seal from sealing. Use any traditional workshop cleaning agent.

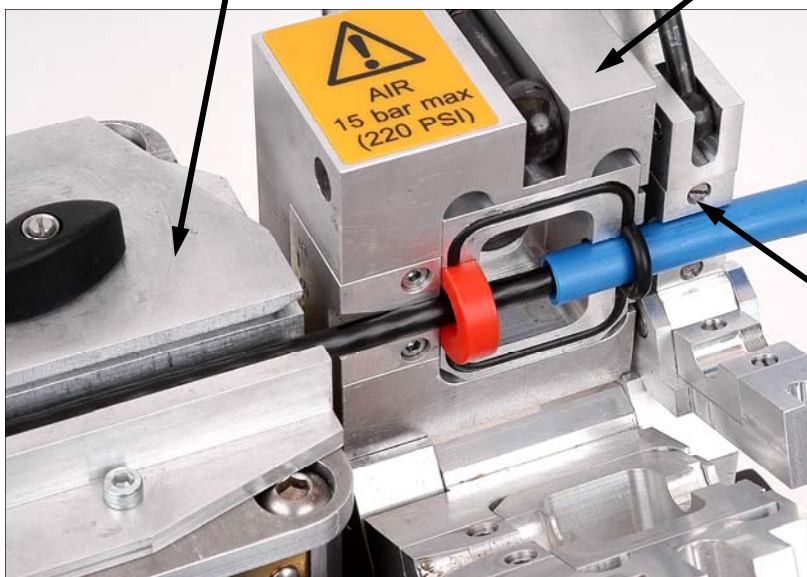

**Tube clamp inserts:** Keep clean. A build up of moisture and dust, particularly in the grooves, will reduce the clamping effect. Use any traditional workshop cleaning agent.

As a general rule, every time an interchangeable part is removed and replaced by a part of a different size, shape etc. the part being removed should be thoroughly cleaned before being returned to its box. Similarly the cavity from which it was removed can also be cleaned prior to the assembly of the replacement part.

The machine should be returned to the General Machine Products Co., Inc., Trevese, Pa. after every 1000 hours use (or at intervals of 12 months) for a major service. The service will include the following.

- Strip down the machine.
- Clean and inspect all parts for damage, replace as necessary.
- Check all screws and fixings for damage, replace as necessary.
- Check all bearings for smooth running, replace as necessary.
- Check all electrical connections for continuity and damage, remake connections and/or replace connectors as necessary.
- Check all air box connections and insert seatings, polish out any marks and scratches to guarantee sealing face integrity. Replace any badly damaged parts which compromise sealing integrity as necessary.
- Replace the motor brushes.
- Replace lower housing seals.
- Replace the drive shaft seal housing "O" rings.
- Rebuild the machine, to current build standard.
- Test.

## 7. Procedure for changing inserts in the tube clamp

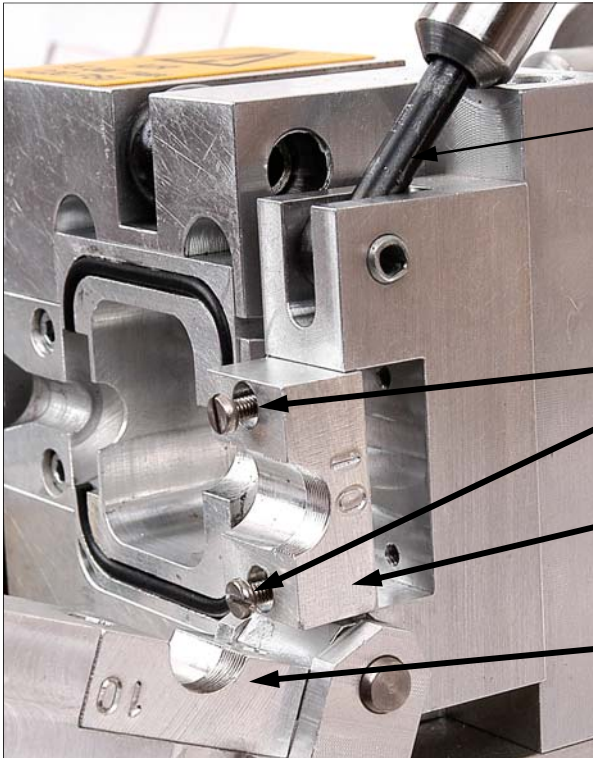

Loosen the thumb nut, rotate the swing bolt to open the tube clamp

Loosen and remove the two fixing screws. (Do not lose these screws, they will be needed for the replacement insert).

Remove the insert

Repeat the process for the insert in the other housing half

To fit the new inserts, reverse the disassembly procedure.

## 8. Procedure for changing inserts in air box

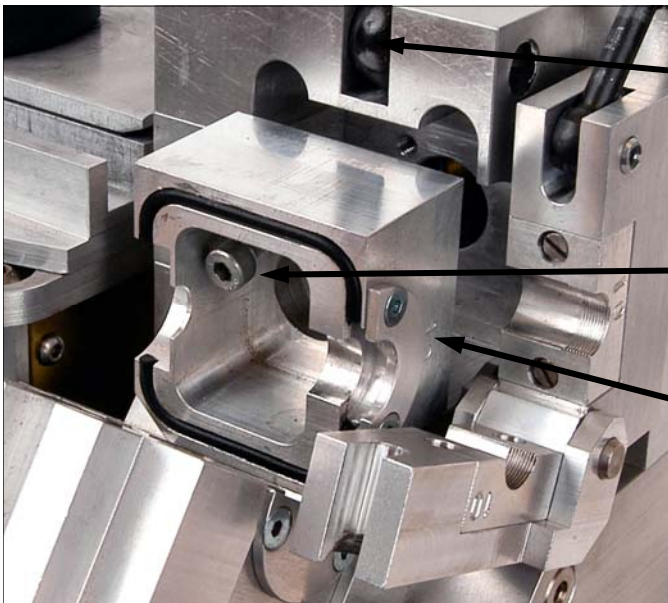

Loosen the thumb nut, rotate the swing bolt to open the air box

Loosen and remove the fixing screw. (Do not lose this screw, it will be needed for the replacement insert)

Remove the insert

Repeat the process for the insert in the other box half

To fit the new inserts, reverse the disassembly procedure.

## 9. Procedure for changing inserts in the in-feed guide

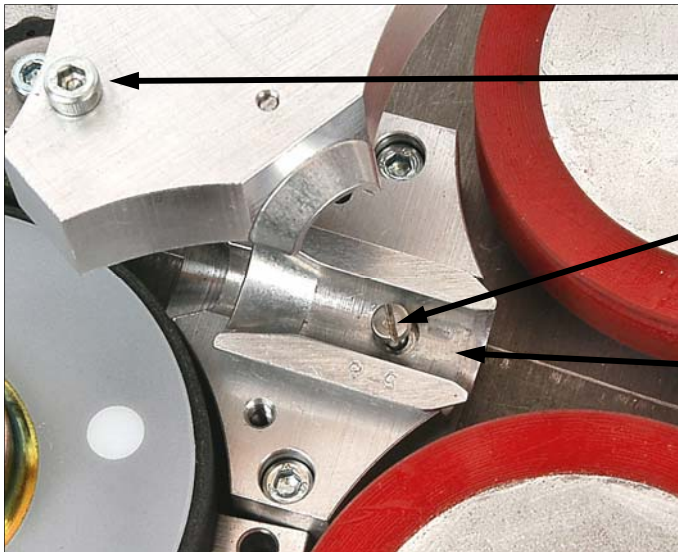

Loosen and remove the two screws securing the upper housing onto the lower housing

Loosen and remove the screw securing the insert into the upper housing

Remove the insert

Repeat the process for the insert in the other housing half

To fit the new inserts, reverse the disassembly procedure.

## 10. Procedure for re-positioning the measuring system fixed roller

(It will be necessary to adjust the position of the roller. This roller provides support for the measuring wheel. It should be positioned so that the measuring wheel does not deflect the cable.

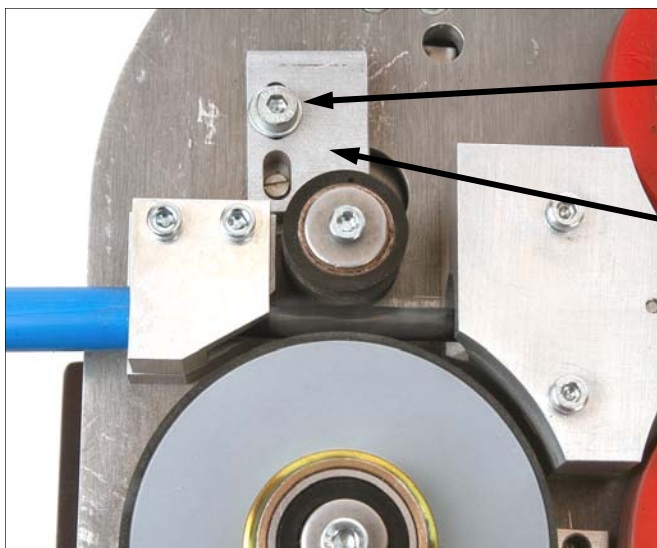

Loosen the screw holding the roller support bracket in position

Position the bracket so that the roller is in light contact with the new cable. Tighten the screw.

## 11. Procedure for replacing the air box housing seal



Cut a length of 0.08inch sealing material 2 1/8" long (a little longer than is necessary).

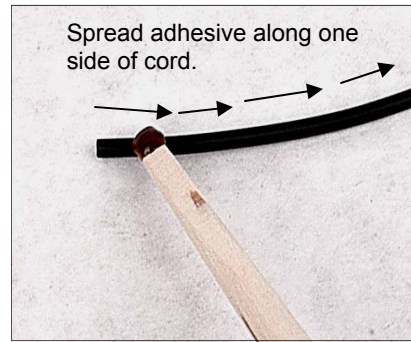

Apply a thin coat of 3M Rubber and Gasket Adhesive to the top of the cut sealing material



Place the pre-cut length in the groove, glue surface down, starting at the end with the retainer plate and aligning flush with the end of the groove.



Work your way around, pressing the seal into the groove and allowing the excess material to hang over the opposite side.

Repeat the procedure for the second groove

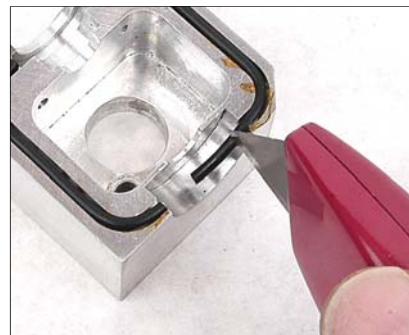

Trim excess material flush with end of groove.

## 12. Procedure for changing the air-box in-feed guide

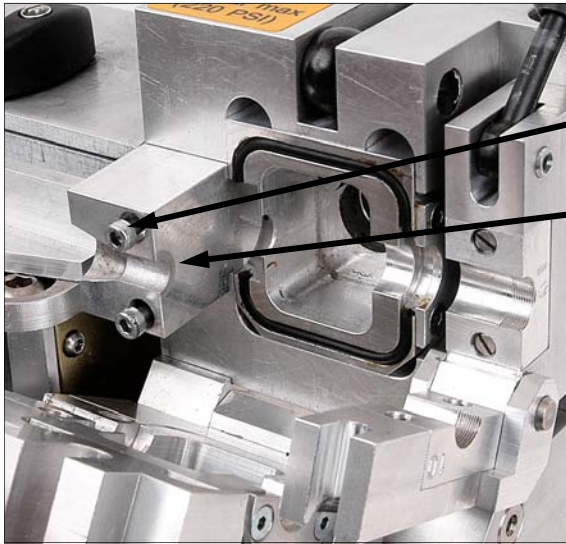

Loosen and remove the two retaining screws. (Do not mislay these screws, they will be needed for the new in-feed guide.)

Remove the air box in-feed guide

Repeat the procedure for the infeed guide insert in the other housing half

**To install the new guides, reverse the dis-assembly procedure**

## 13. Procedure for changing the drive rollers

The machine is fitted with standard rollers, Tests have shown that these rollers give a good compromise of life and grip. There may be circumstances when a roller with much higher grip will be needed. If, for instance it is necessary to install a cable which will sustain crushing damage when light compression forces are applied to it. It will be necessary to use a roller with a surface coating with high friction characteristics. This will allow the cable to be pushed with high torque while being compressed lightly. If this type of roller is needed, the GMP sales office will be able to advise on part numbers etc. To install this roller it will be necessary to remove the standard roller, with the procedure as follows.



Loosen and remove the retaining screw and washer



Remove the roller

Repeat the procedure for the other roller

**To fit the new rollers, reverse the assembly procedure**

# 14. Blown Fiber Conversion (1.1mm and 1.6mm) with 5mm Micro Duct

Parts required for a 12 count blown fiber conversion are available in a kit form.

## Blowing Tips:

- Insert a 2" piece of 5mm tubing in the In-Feed Clamp Assy.
- The measuring fixed roller should be adjusted so that just enough pressure is on the fiber to turn the measuring wheel without deflecting it.
- Set the tube in the air box as shown in photo to right. This prevents possible buckling of the fiber in the air box.
  - Feed the fiber along the guides and into the tube, making sure that the fiber is centered in the guides before you close the air box.
- Ensure that the fiber feeds freely through the Breeze and into the tube manually before setting the drive rollers.

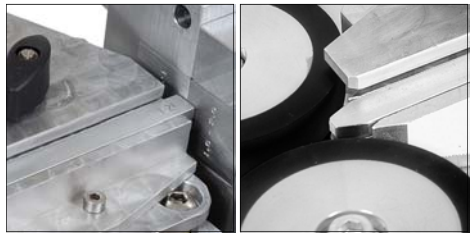
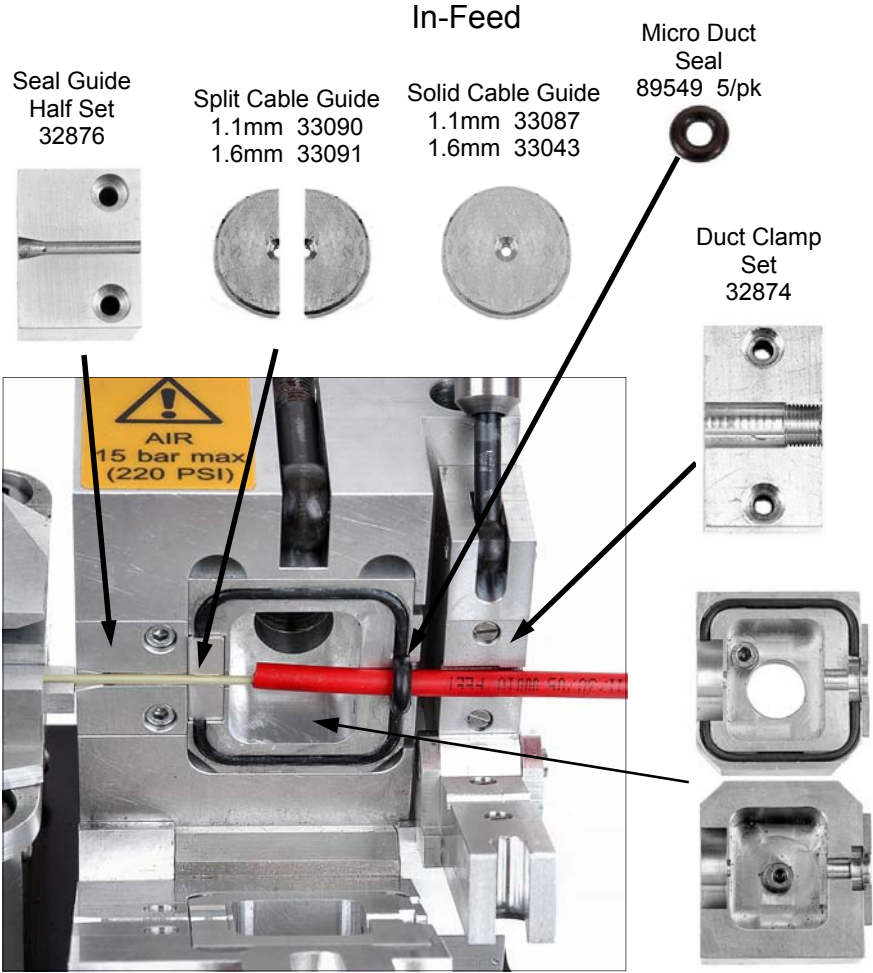
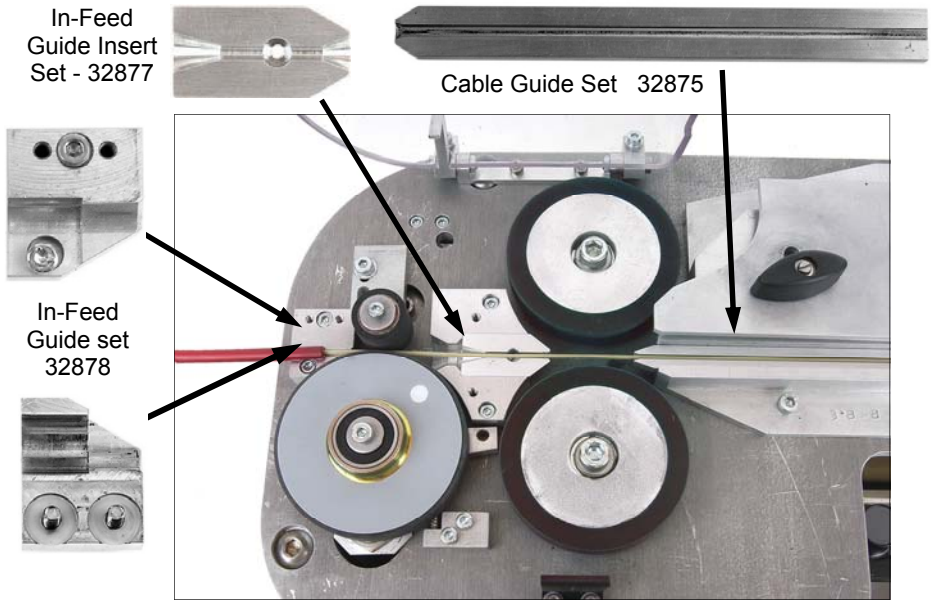

**Note:** Cable guide must be inserted against the air box to insure clearance for the rollers. **Failure to do so will result in damage to the drive wheels.**

Out-Feed

Air Box Assy 32879



## 15. Monthly service – check list

This section includes a list of suggested checks, it is recommended that these checks be carried out on a regular basis, depending on use. Monthly checks are convenient; a few minutes can be set aside on the same day of each month to complete these simple checks. The next section of this manual is an empty table, the dates when these checks and all other service and repair jobs are completed can be entered into the spaces provided in this table. This will give the user a record of what service has been carried out and when.

1. Check the tool box, insure all tools and interchangeable parts are present, clean and ready for use.
2. Clean the outside of the machine, take care not to damage the rollers or springs.
3. Check the measuring wheel, insure it runs freely, and that the speed/distance functions respond when the wheel is rotated.
4. Check the measuring wheel fixed roller, make sure it rotates freely.
5. Loosen the thumb nuts locking the top plate of the cable guide (out-feed) in position, insure the plate is free to move backwards and forwards.
6. Clean the exposed threads on the swing bolts that hold the air box and tube clamp assembly together. Add a smear of grease/oil\* to prevent build up of surface corrosion and to insure smooth operation of the thumb nuts.

\*Care should be given not to expose the drive wheels to any grease or oil.



## 17. Tube integrity and Lubrication

**This is entirely the responsibility of the operator.**

To be sure that the tube into which the cable is to be inserted is installed appropriately, it is recommended that its integrity and lubrication be checked.

### Check that the tube is:

1. Not blocked
2. Not crushed
3. Continuous (no breaks)
4. Also check that any joins are pressure tight
5. Finally check that the tube is appropriately lubricated

The easiest and most straightforward way to complete these checks is to set the machine up for a normal cable insertion but fit a seal in place of the cable. The tube can then be pressurized without running the roller drive.

**CAUTION:** Any object inadvertently left in the tube during the tube laying may be expelled from the end of the tube with high force and velocity. It is imperative that no personnel be in the vicinity of the end of the tube or that a suitable device is fitted to the end of the tube to arrest any expelled object.

The checks listed at 1-4 (inclusive) above may all be carried out at the same time using one check. The procedure is outlined below. Set up the air box and tube clamp as shown.

Fit the appropriate plug as shown (see appendix for plug number).

Fit the air box seal, tube and tube seal in position as for normal cable installation.

When the air box has been set up as shown in the photo, the air box and tube clamp should be closed as for usual cable installation.

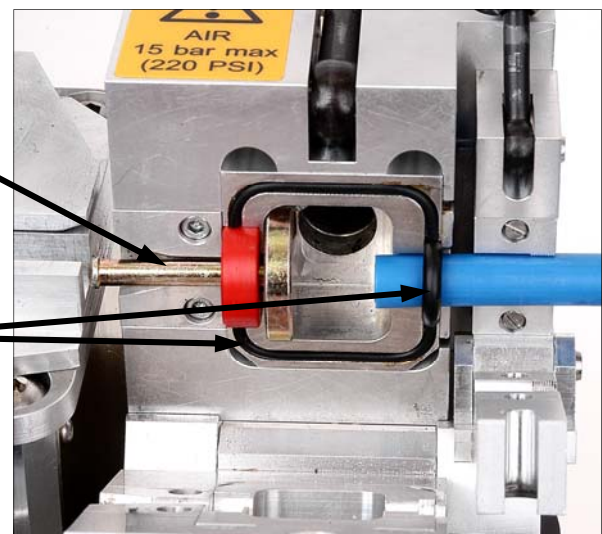

*Continued on next page*

The air box and tube clamp are now set up to blow air through the tube.

1. Connect the air as for normal blowing.
2. Make sure there are personnel at the other end of the tube run, and that they are aware that the air is to be turned on.
3. Make sure that a suitable device is fitted to obviate injury should any object be expelled from the far end of the tube.
4. Apply air to the Breeze

The far end of the tube run should be monitored; air should be leaving the tube under reasonable pressure. The minimum pressure required will vary with the length of tube in the run, the friction characteristics of the tube, the cable and the lubrication being used. As a starting point, the air leaving the far end of the tube should be (at least) similar to a light breeze. Bear in mind that if the tube run is of considerable distance, it may take a few minutes for the air to reach the far end of the tube.

If after waiting a suitable time there is no air leaving the far end of the tube, this would indicate that there is a blockage or similar obstruction in the tube run, or, that the tube is fractured. In either case the fault should be corrected before any attempt is made to blow cable through the tube.

Once the tube integrity has been confirmed by the method outlined above. The tube may be lubricated.

1. Open the air box and tube clamp assembly, withdraw the tube and raise it so that the lubricant will pour into it easily and not overflow from the top.
2. Pour lubricant (available through GMP) of recommended quality and quantity down the tube. (a recommended quantity is 3.5 fl oz per 3200 feet of tube length).
3. Insert a suitable foam plug into the tube and put the tube back into the air box and tube clamp.

The air box and tube clamp assembly are now set up to blow the foam plug through the tube and deposit an even coating of lubricant to the inside walls of the tube.

1. Connect the air as for normal blowing.
2. Make sure there are personnel at the other end of the tube run, and that they are aware that the air is to be turned on. Make sure that a suitable device is fitted to obviate injury should any object be expelled from the far end of the tube.
3. Apply air to the Breeze

When the foam plug has been expelled from the far end of the tube run, cable can be installed into the tube.

**Note:** When the air is turned off, after checking the tube integrity and sending the foam plug down the tube to spread the lubricant, it may take some time for the pressure in the tube to fall back to low levels.

## 18. Recommended spares list

1. Tube Seals
2. Cable Seals
3. Drive Rollers
4. Cable end tips
5. Lubricant
6. Seal Cord
7. 5 A and 325 mA fuses

**Note:** See page 32 for part numbers or contact GMP customer service department.

For spare parts always quote the machine type and serial number and contact:



**General Machine Products Co., Inc.**  
3111 Old Lincoln Highway, Trevose PA 19053 USA

TEL: +1 215 357 5500  
FAX: +1 215 357 6216  
E-MAIL: [info@GMPtools.com](mailto:info@GMPtools.com)  
Website: [www.GMPtools.com](http://www.GMPtools.com)

Page intentionally left blank

# 1. APPENDIX 1

This section lists the appropriate inserts, collets, etc required for a given cable/tube combination. The ***bold italicized*** numbers in the table are cable/tube identification numbers which are marked on the individual components. (Twelve count (1.6mm) conversion is found on page 25.)

Cable size (O/D)	Photo	2.5-3.0mm (.098"-.118")	3.0-3.8mm (.118"-.150")	3.8-5.0mm (.150"-.197")	5.0-6.4mm (.197"-.250")	6.4-8.0mm (.250"-.315")
Infeed Guide Insert Set	A	<b><i>2.5-3.0</i></b> P/N 32885	<b><i>3.0-5.0</i></b> P/N 32886	<b><i>3.0-5.0</i></b> P/N 32886	<b><i>5.0-8.0</i></b> P/N 32883	<b><i>5.0-8.0</i></b> P/N 32883
Seal Guide Half Set	B	<b><i>2.5-3.0</i></b> P/N 32889	<b><i>3.0-3.8</i></b> P/N 32890	<b><i>3.8-5.0</i></b> P/N 32891	<b><i>5.0-6.4</i></b> P/N 32884	<b><i>6.4-8.0</i></b> P/N 32892
Cable seal (5/pk)	C	P/N 89510	P/N 89511	P/N 89512	P/N 89513	P/N 89514

Tube size (O/D)	Photo	5.0mm	8.0mm	10.0mm	12.0mm	12.7mm	16.0mm
In-Feed Guide Set	D	P/N 32878	P/N 32893	P/N 32881	P/N 32909	P/N 32913	P/N 32821
Micro Duct Seals (5 pk)	E	P/N 89549	P/N 89550	P/N 89551	P/N 89552	P/N 89552	P/N 89554
Airbox Set	F	P/N 32879	P/N 32888	P/N 32882	P/N 32908	P/N 32912	P/N 32915
Insert Clamp Set	G	P/N 32874	P/N 32894	P/N 32880	P/N 32911	P/N 32914	P/N 32917

### Cable Kits (A,B,C Included)

Cable Size	P/N
2.5 - 3.0 mm	89530
3.0 - 3.8 mm	89531
3.8 - 5.0 mm	89532
5.0 - 6.4 mm	89533
6.4 - 8.0 mm	89534

### Tube Kits (E,F,G,H Included)

Tube O.D	P/N
5 mm	89539
8 mm	89540
10 mm	89541
12 mm	89542
12.7 mm	89543
16 mm	89544

### Cable Guide Sets

Cable Range	P/N
2.5 - 3.8 mm	89520
3.8 - 8.0 mm	89521

NOT TO SCALE

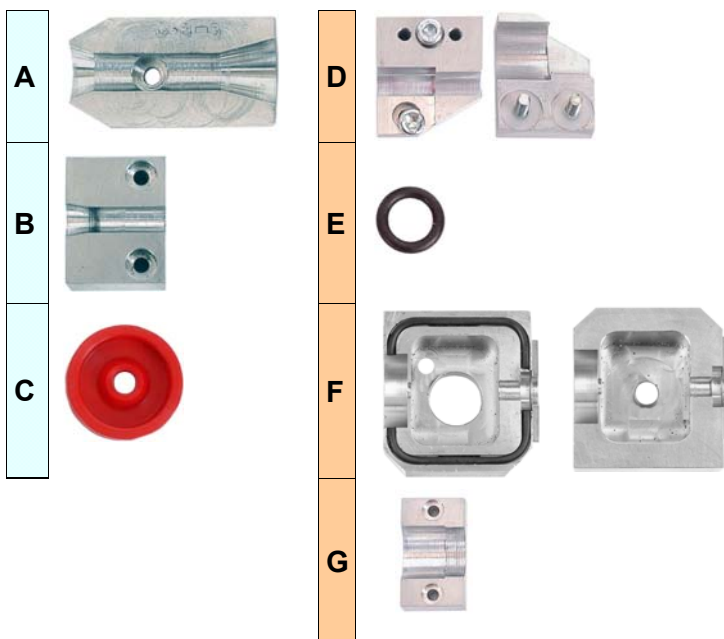

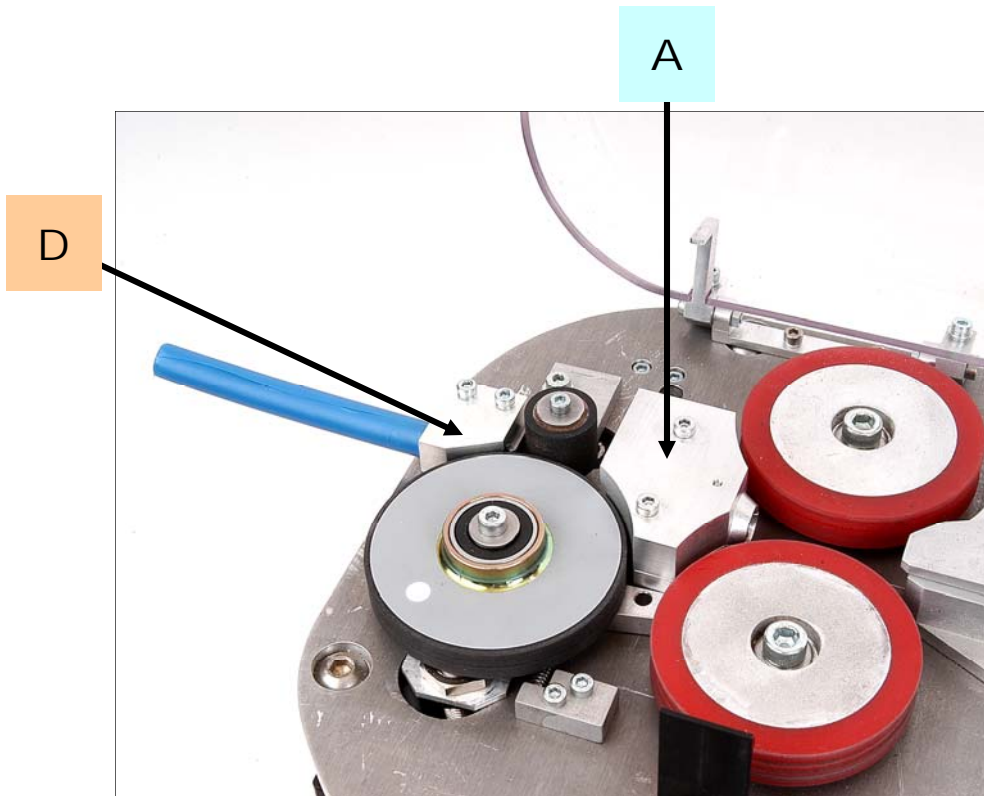
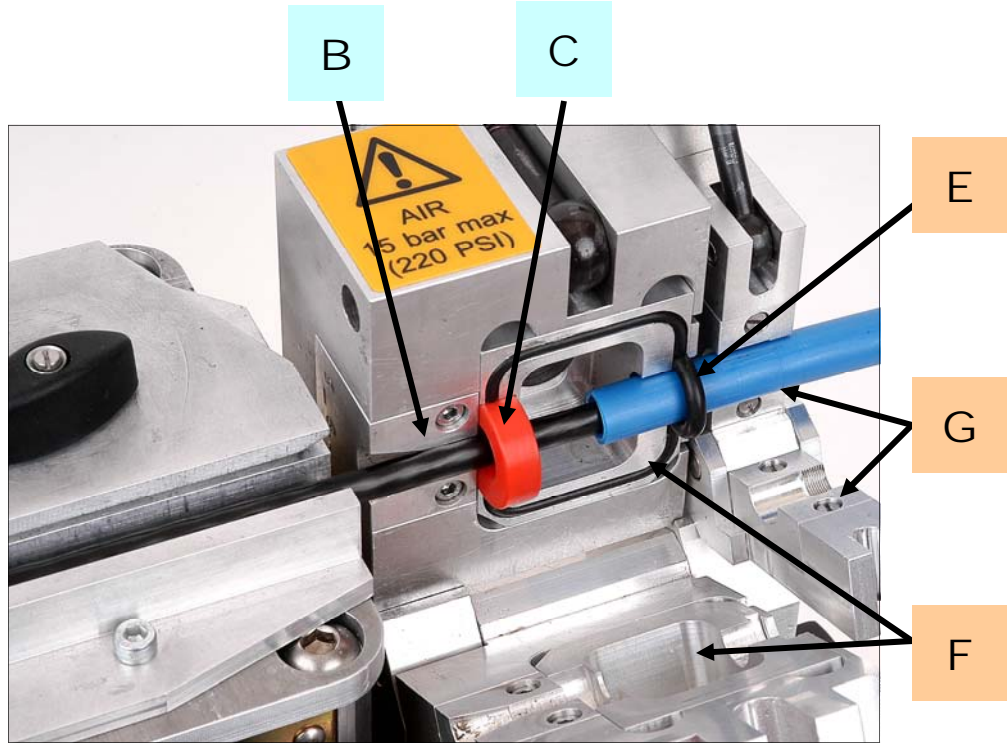

## 2. APPENDIX 2

This section makes recommendations for the initial setting of the torque control potentiometer when installing a cable which has not been installed before, and, whose characteristics are unknown.

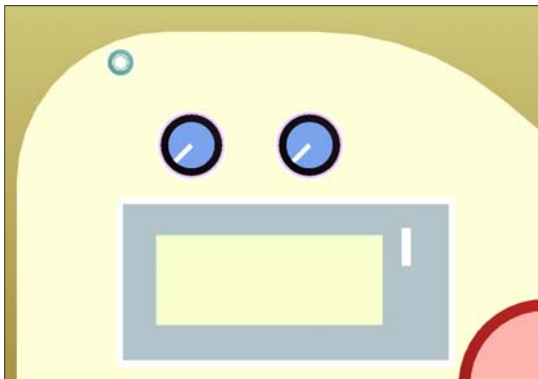

The diagram to the left shows the torque and speed control knobs set in the maximum counter-clockwise position. In this position both torque and speed will be minimum. (Zero)

The diagram to the right shows the torque and speed control knobs set in the maximum clockwise position. In this position both torque and speed will be maximum (see specification for details).

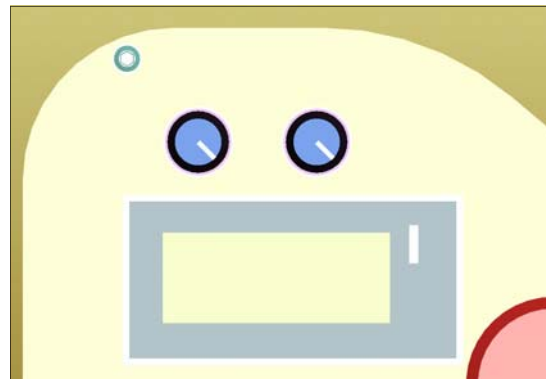

The torque control setting will allow the cable to be installed efficiently and without damage. It is of vital importance that the torque setting is made with great care, a little time spent understanding the way to arrive at the optimum settings will save time and frustration during the installation. There are two stages to arriving at the correct torque setting they are described below.

1. Establish the stiffness coefficient from the table below: the stiffness coefficient is a figure used to represent the diameter and the stiffness of a cable. This figure is only relevant in the context of setting the torque, it has no other relevance. The higher the U figure the stiffer the cable. There is a degree of subjectivity about determining the cable stiffness. What is low stiffness? What is high stiffness? Determining this (the stiffness) relies upon the user having some familiarity with bundled optical fiber cables, this will give the experience to assess whether the cable has low, medium or high stiffness. For instance a small diameter cable with high stiffness may be less stiff than a large cable with medium stiffness. The table reflects this. If there is any doubt, in the first instance err on the low side, i.e. select a lower U figure.

Cable diameter	Cable stiffness	Stiffness coefficient (U)
0.078" – 0.138"	Low	U1
	Medium	U1
	High	U2
0.138" – 0.197"	Low	U1
	Medium	U2
	High	U3
0.197" – 0.256"	Low	U2
	Medium	U3
	High	U5
0.256" – 0.315"	Low	U2
	Medium	U4
	High	U6

2. Assess the coefficient of friction of the cable insulation (the outer coating). Is it low or high? Once again this relies on the user having some experience with bundled optical fiber cables. As a guide, if the surface feels smooth and dry the coefficient of friction will be low, if you slide your hand over the surface does it snatch your flesh? If it does the coefficient of friction will be high. As above, if there is any doubt, err on the low side i.e. select a lower coefficient of friction.

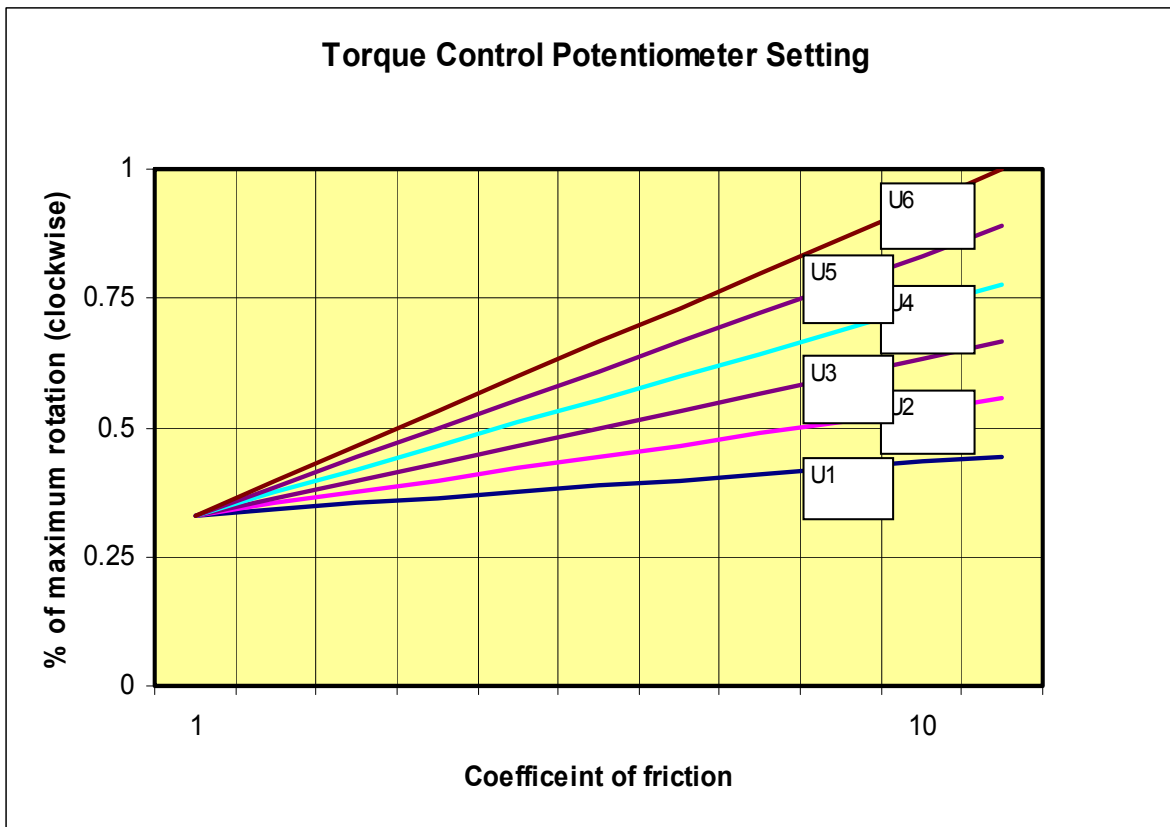

3. Referring to the chart above. The “x” axis (the bottom line) represents the coefficient of friction; 1 is very low: 10 is very high. Look along this line from left to right. Pick a vertical line that is approximately the value of the coefficient of friction. Look vertically upward along this line. It crosses a series of angled lines, these lines are numbered U1, U2 etc. where the vertical line crosses the angled line with the U figure determined from step 1 make a mark on the chart. Draw a horizontal line (parallel with the other horizontal lines on the chart) from the marked point. Where this line crosses the “y” axis (the vertical line at the extreme left hand of the chart), make a second mark on the chart. The height of this line represents the % of maximum clockwise rotation of the torque control. If this line is very close to the figure 0.5 marked on the “y” axis, set the torque control potentiometer approximately one half of the way around its maximum travel etc.

There is an alternative way of arriving at the appropriate setting for the torque control potentiometer.

Do the following:

Select a sample of the cable to be used. Pass the cable through the machine as described in the manual. Feed the cable into the beginning of a length of sample tube (say 5 metres long). Seal the open end of the tube. Position the torque control potentiometer at the position determined by the recommendations in this appendix, Start the machine. Drive the cable hard into the sealed end of the sample length of tube. The rollers will stop turning, this is because the torque limit has been reached. Repeat this procedure, each time turning the torque potentiometer a little further clockwise. Eventually, the cable will buckle. The setting of the torque control potentiometer is now a little too far clockwise. Turn it back (counter clockwise) a little. This is the optimum setting.

*Continued on next page*

**Note:**

This method may also be used to set the clamping force of the rollers on the cable. Initially, the clamp arm lever should be set so that the rollers press very lightly onto the cable. Carry out the test outlined above (drive the cable into the closed end of a sample tube). The rollers will slip. Repeat this procedure, each time increasing slightly, the pressure the rollers apply to the cable. Eventually the rollers will stop turning because the torque limit has been reached. It is worth noting at this stage that this approach may result in a great deal of force being applied to the cable. More than the cable can withstand without sustaining damage, sometimes it may be that the cable may be protected from buckling by a combination of torque control setting and slip. The main purpose of the exercise is to install the cable as far as possible without causing damage to the outer sheath, in some circumstances a compromise may be found that uses a degree of torque control and slip.

### 3. APPENDIX 3

#### Programming Parameters for CUB5B counter/rate meter fitted to Breeze machines— Nov 2005 Onwards.

The device must be wired and installed into the machine prior to programming.

Breeze is fitted with C-M-DEV-CUB5B, backlight version.  
The DIP switch positions are as follows:

- 1 OFF
- 2 OFF
- 3 OFF
- 4 OFF

Please see the attached CUB5 Programming Overview attached to this document.



**DIP Switch**

- a. Press and hold SEL for 2 seconds to enter programming mode
- b. Enter the Pro-Code-111 (a general code of 222 may also work)
- c. Press and Hold SEL for 2 seconds
- d. Pro-no should now be flashing, press RST
- e. Press RST to move through the various sections 1-input, 2-rate etc.
- f. Press SEL to enter that section
- g. To change the value of a parameter press RST
- h. Press SEL to move to the next parameter
- i. When all the parameters in the section have been scrolled through you will return to the Pro-no display, press RST to scroll to another section else press SEL to exit programming mode.



**CUB5B counter/rate meter**

## Counter programming parameters for the Breeze machine:

---

Press RST Once:

### Counter Parameters (1-INPUT)

INPA-B = Cnt ud - if correct press SEL.

CNT A DP = 0 - if correct press SEL

CNT A SCF = 0.0102 (METRIC, m) or 0.0335 (Imperial, ft) - once correct press & Hold SEL

CNT A RST = TO ZERO - if correct press SEL

CNT A DIR = NOR - if correct press SEL

CNT A LD = 0 - once correct press & Hold SEL

RST P- UP = NO - if correct press SEL

USER INP = NO - if correct press SEL

Press RST Twice

### Rate Parameters (2-RATE)

RATE ENB = YES - if correct press SEL

RATE DP = 0 - if correct press SEL

RATE DSP = 60 - once correct press & Hold SEL

RATE INP = 97.9 (Metric, m/min) or 29.8 (Imperial, ft/min) - once correct press & Hold SEL

LO-UDT = 1.0 - if correct press SEL

HI-UDT = 2.0 - if correct press SEL

Press RST Three Times

### DISPLAY (3-DSPRAY)

SEL ENB = YES - if correct press SEL

RST ENB = YES - if correct press SEL

D-SCROLL = NO - if correct press SEL

D-COLOR = RED - if correct press SEL

D-LEVEL = 5 - if correct press SEL

PRO CODE = 111—CODE REQUIRED TO RE-PROGRAM - once correct press & Hold SEL

CODE VER = NO - if correct press SEL

FACT SET = NO - Press SEL Twice



Page intentionally left blank

## **GMP Limited Warranty**

**1a.** General Machine Products Co., Inc. ("GMP") warrants to the purchaser and/or end user:

(1) that a new product sold and manufactured by GMP will be free from original defects in material and workmanship for one year from the date the product was delivered to the purchaser and/or end user, or for the lifetime of the Modular Plug Presser;

(2) that a new product sold and not manufactured by GMP will be covered exclusively by the manufacturer's warranty. However, if that warranty coverage shall provide less coverage than the GMP Warranty for its manufactured products, then the warranty set forth in Paragraph 1(a)(1) above shall apply instead;

(3) that a reconditioned used GMP product sold by GMP, or a non-owned product repaired by GMP, or a new part sold by GMP, will be free from original defects in material and workmanship for ninety days from the date the product was delivered to the purchaser and/or end user.

**1b.** The above warranties are contingent upon and subject to the condition that: (1) the end user substantiates the date it purchased and received delivery of the product or part, and (2) the product or part shall have been installed, maintained and used in accordance with GMP's or the manufacturer's written instructions.

**2.** The end user shall determine the suitability of GMP's product or part for intended use, and the end user assumes all risk and liability whatsoever in connection therewith except to the extent set forth in this Limited Warranty.

**3a.** GMP reserves the right to request that the product or part be returned to us for examination and cannot be responsible for user charges incurred in the replacement of any product. GMP's agreement to repair or replace is also subject to its inspection of the product and verification of the defect.

**3b.** Subject to immediate written notification of a defect or malfunction, GMP will repair or replace that product or part, at GMP's option, returned freight prepaid to Trevose, PA.

**3c.** To obtain repair or replacement service under the Limited Warranty, the purchaser must contact the factory for a Return Material Authorization (RMA). Once obtained, send the RMA along with the defective part or product, transportation prepaid to:

**General Machine Products Co., Inc.**      Tel: 215.357.5500  
3111 Old Lincoln Highway              Fax: 215.357.6216  
Trevose, PA 19053-4996 USA

**3d.** The field labor and material charges incurred by an authorized GMP dealer or an end user to disassemble, inspect, repair and reassemble our product or part at their respective prime locations will not be reimbursed unless GMP has first reviewed and approved those charges.

**3e.** Incidental repair charges incurred by an authorized dealer or an end user for items such as labor, transportation, tolls, lodging and meals at a location remote from its prime facility, or to demount our product or part from its remote location and forward to its prime facility, are not the responsibility of GMP, and are not covered by this Warranty.

**3f.** Incidental repair charges incurred by an authorized GMP dealer or end user to remove construction hardware, modify a vehicle or otherwise gain access to GMP's product or part, is a condition beyond GMP's control, and is not covered by this Warranty.



**4a.** GMP products or parts which become part of a total assembly which has been designated and/or manufactured by others, are not covered by this Warranty unless GMP reviews the total assembly and expressly extends its warranty.

**4b.** Design, material and workmanship furnished by others to install or operate a GMP product or part are not covered by this Warranty with respect to GMP's products or parts which are used in that particular assembly.

**4c.** Hydraulic, pneumatic, electrical or mechanical control equipment which is not manufactured by GMP and which becomes a part of a GMP assembly, is not covered by this Warranty.

**4d.** This warranty does not cover a GMP product or part which others have subjected to abuse, improper installation, improper operation, alteration or negligence in storage or handling.

**5a.** THE ABOVE WARRANTIES ARE EXCLUSIVE AND ARE IN LIEU OF ALL WARRANTIES OF MERCHANTABILITY, FITNESS FOR PURPOSE OR OTHER WARRANTIES OR GUARANTEES OF ANY KIND OR DESCRIPTION, EXPRESS OR IMPLIED.

**5c.** GMP'S SOLE LIABILITY AND THE PURCHASER'S SOLE REMEDY FOR A FAILURE OF A PRODUCT OR PART UNDER THIS LIMITED WARRANTY, AND FOR ANY AND ALL CLAIMS ARISING OUT OF THE PURCHASE AND USE OF THE PRODUCT OR PART SHALL BE LIMITED TO THE REPAIR OR REPLACEMENT OF THE PRODUCT OR PART THAT DOES NOT CONFORM TO THIS WARRANTY.

**6.** GMP reserves the right, without notice, to make changes in equipment design or components as progress in engineering or manufacturing methods may warrant.

**7.** This Warranty shall be construed in accordance with the laws of the State of Pennsylvania, of The United States of America.

**8.** This Limited Warranty may not be modified, in whole or in part, except by writing signed by an authorized officer of GMP.



GMP • 3111 Old Lincoln Hwy • Trevose, PA 19053 • USA  
TEL: +1-215-357-5500 • FAX: +1-215-357-6216 • EMAIL: [info@gmptools.com](mailto:info@gmptools.com)

