

**MODEL UG-22
MODEL UG-28
INTERMITTENT DUTY WINCH
PARTS LISTS & ASSEMBLY DRAWINGS**

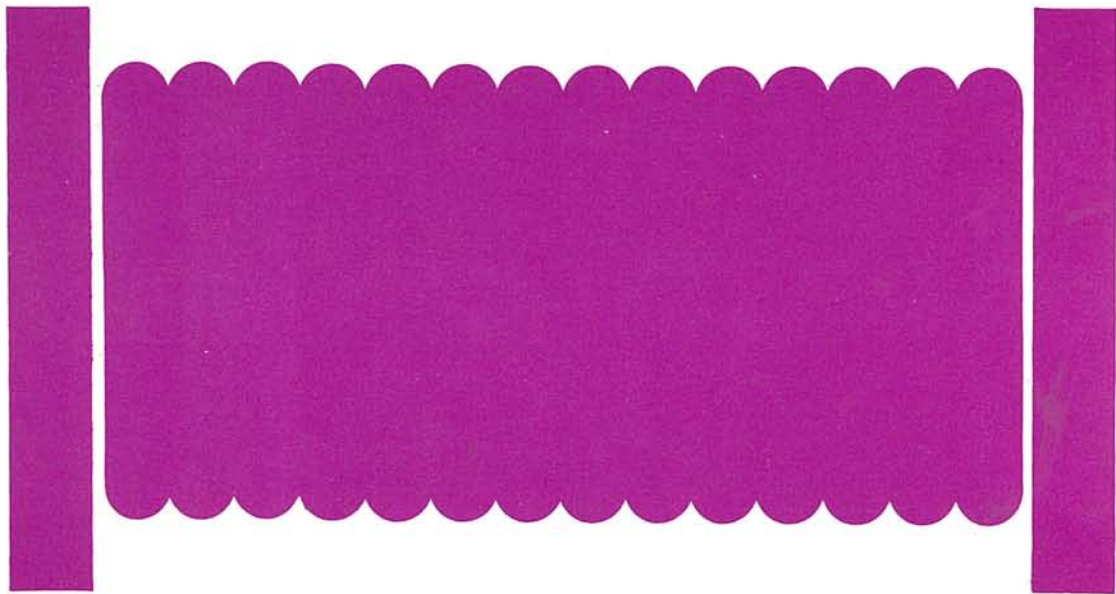

ADAMS EQUIPMENT
A DIVISION OF
GENERAL MACHINE PRODUCTS CO. INC.
3111 Old Lincoln Hwy Trevose, PA 19053

INDEX

	Page
General Arrangement.....	2
General Assembly Parts Drawing.....	3
General Assembly Parts List.....	4
Drive Assembly Parts Drawing.....	5
Drive Assembly Parts List.....	6
Worm Assembly Parts Drawing.....	7
Worm Assembly Parts List.....	8
Safety Brake Assembly Parts Drawing.....	9
Safety Brake Assembly Parts List.....	10
Clutch & Disc Brake Assembly Parts Drawing.....	11
Clutch & Disc Brake Assembly Parts List.....	12
Band Brake Assembly Parts Drawing.....	13
Band Brake Assembly Parts List.....	14

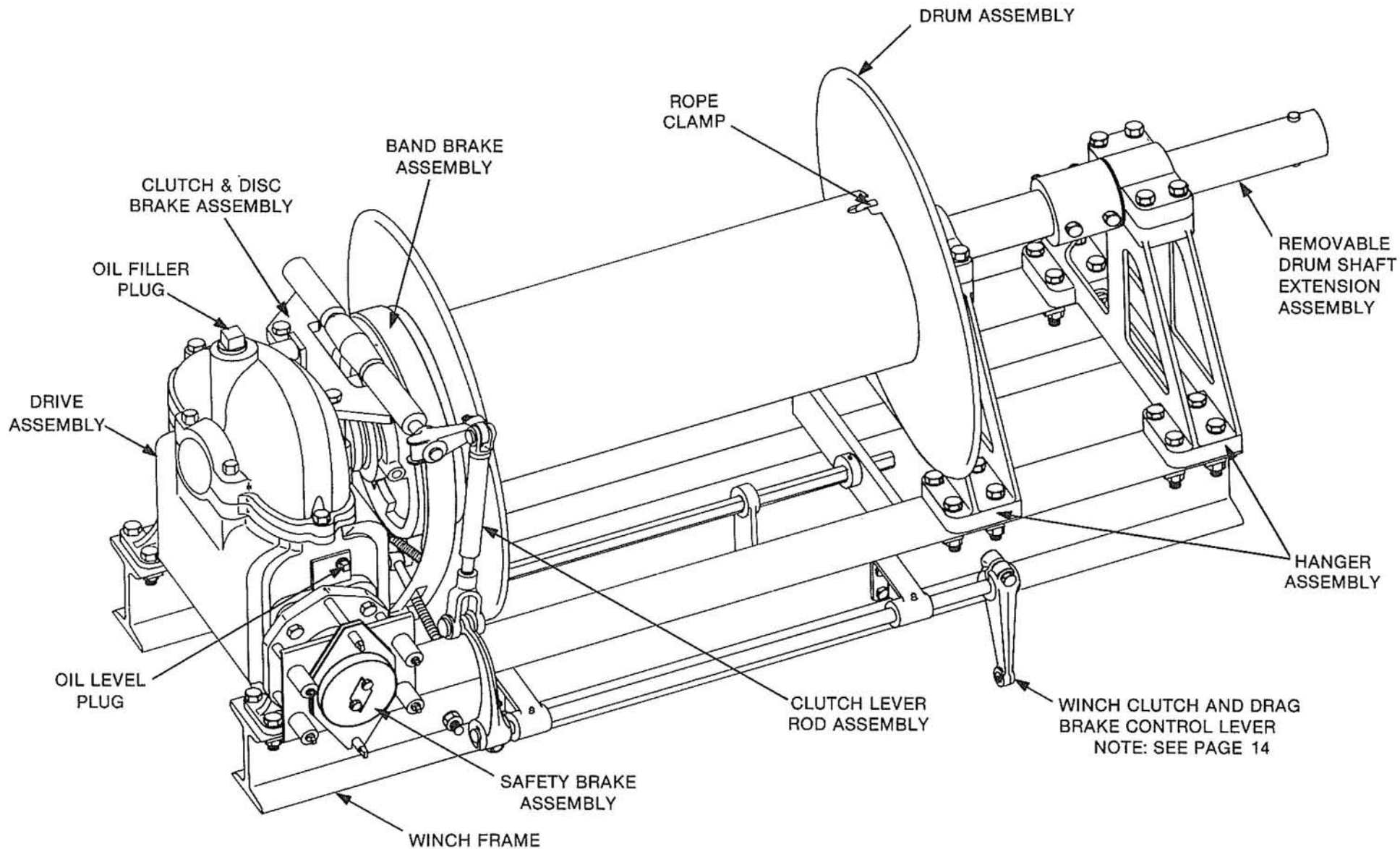

FIG. 1 — GENERAL ARRANGEMENT

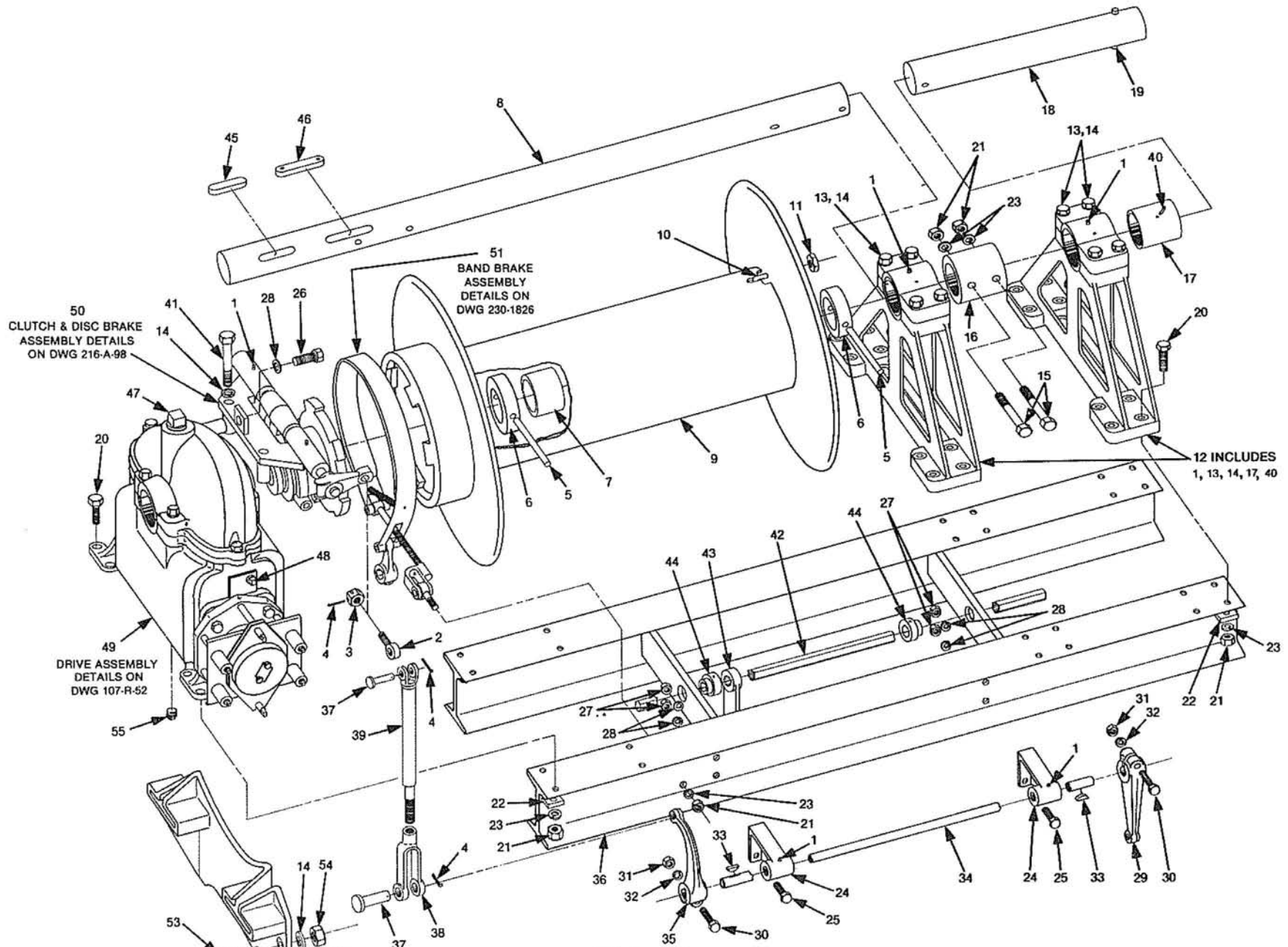
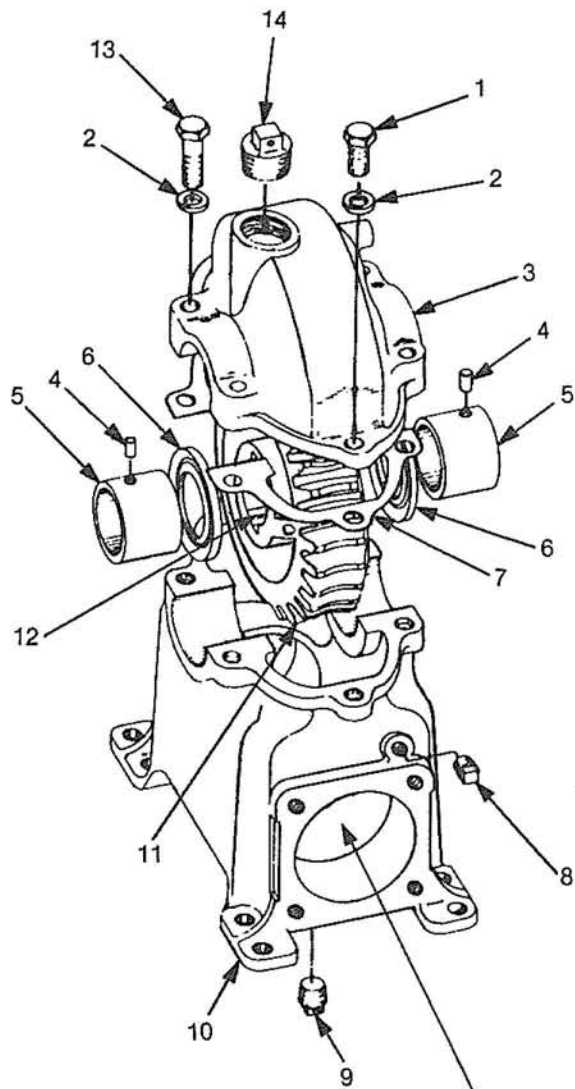

FIG. 2
GENERAL ASSEMBLY PARTS DRAWING

GENERAL ASSEMBLY PARTS LIST
FIG. 2

ITEM	PART NAME	PART NO.	QTY	ITEM	PART NAME	PART NO.	QTY
1	Fitting, Lubrication	5030	6	29	Lever, Clutch Rod	127-S-20	1
2	Rod End, Clutch Yoke Shaft Lever	151-E-50	1	30	Screw, Hex Hd Cap 5/16-24 UNF x 1-3/4	Com'l	2
3	Nut, Castle 1/2-20 UNF	Com'l	1	31	Nut, Hex 5/16-24 UNF	Com'l	2
4	Pin, Cotter 3/32 x 1	Com'l	3	32	Washer, Lock 5/16 SAE Med.	Com'l	2
5	Pin, Taper #7 x 4	Com'l	2	33	Key, Woodruff 1/4 x 7/8	807	2
6	Collar, Drum Thrust	104-E-52	2	34	Shaft, Clutch Lever		
7	Bushing, Drum	104-E-51	2		UG-22	230-1531-2	1
8	Drum Shaft				UG-28	230-1531-3	1
	UG-22	230-1529-2	1	35	Lever, Clutch Rod Shaft	4H818	1
	UG-28	230-1529-3	1	36	Frame		
9	Drum Assembly				UG-22	230-1528-2	1
	UG-22	230-1535A-2	1		UG-28	230-1528-3	1
	UG-28	230-1535A-3	1	37	Pin, Rod End	27081/2-6A	2
10	Clamp, Rope	230-1547	1	38	Rod End	2708-6A	1
11	Nut, Rope Clamp	230-1548	1	39	Rod Assembly, Clutch Lever	127-S-26	1
12	Hanger Assembly	274-B-73A	2	40	Pin, Driv-Lok 1/4 x 1/2 Type B	Com'l	2
13	Screw, Hex Hd Cap 5/8-18 UNF x 2	Com'l	8	41	Screw, Hex HD Cap 5/8-18 UNF x 4-1/2	Com'l	2
14	Washer, Lock 5/8 SAE Med.	Com'l	26	42	Shaft, Hex	230-1827	1
15	Screw, Hex Hd Cap 1/2-20 UNF x 3-3/4	Com'l	2	43	Lever	230-60W	1
16	Coupling, Drum Shaft	230-20	1	44	Collar, Stop	230-32	2
17	Bushing, Hanger	106-E-79	2	45	Key	104-E-74	2
18	Shaft, Drum Extension	230-22	1	46	Key	104-E-54	2
19	Pin, Spindle	110-E-27	1	47	Plug, Pipe	125-E-45	1
20	Screw, Hex Hd Cap 1/2-20 UNF x 1-3/4	Com'l	24	48	Plug, Pipe 3/8	Com'l	2
21	Nut, Hex 1/2-20 UNF	Com'l	27	49	Drive Assembly	107-R-52	1
22	Washer, Bevel 1/2	Com'l	24	50	Clutch & Disc Brake Assembly	216-A-98	1
23	Washer, Lock 1/2 SAEMed.	Com'l	27	51	Band Brake Assembly	230-1826	1
24	Bracket, Clutch Lever Shaft Assembly	230-1511A	2	52	Bracket, Winch Mounting	285-B-47	2
25	Screw, Hex Hd Cap 3/8-24 UNF x 1-1/4	Com'l	4	53	Bolt, Hex Hd 5/8-18 UNF x 2	147-S-21	16
26	Screw, Hex Hd Cap 3/8-24 UNF x 1	Com'l	1	54	Nut, Hex 5/8-18 UNF	Com'l	16
27	Nut, Hex 3/8-24 UNF	Com'l	4	55	Plug, Pipe 1/2	Com'l	1
28	Washer, Lock 3/8 SAE Med.	Com'l	5				



See Fig. 5 for Safety
 Brake Assembly This End
 See Fig. 4 for Worm
 Assembly Opposite End

FIG. 3 — DRIVE ASSEMBLY PARTS DRAWING

107-R-52

DRIVE ASSEMBLY PARTS LIST
FIG. 3

ITEM	PART NAME	PART NO.	QTY
1	Screw, Cap, Hex Hd 5/8-18 UNF x 1	Com'l	2
2	Washer, Lock 5/8 SAE Med.	Com'l	6
3	Housing, Upper	230-210	1*
4	Pin, Driv-Lok 1/2 x 5/8 Type B	Com'l	2
5	Bushing	104-E-76	2
6	Washer, Thrust	104-E-75	2
7	Gasket	109-E-60	2
8	Plug, Pipe 3/8	Com'l	2
9	Plug, Pipe 1/2	Com'l	1
10	Housing, Lower	230-211	1*
11	Wheel, Worm R.H.	220-B-69	1
12	Key	104-E-74	2
13	Screw, Cap, Hex Hd 5/8-18 UNF x 2	Com'l	4
14	Plug	125-E-45	1

Note:

- * Housing, Upper, Part No. 230-210 and Housing, Lower, Part No. 230-211 are only available as a machined matched set, Part No. 230-1717, includes items 3, 7, 10, 13 and (4) of 2

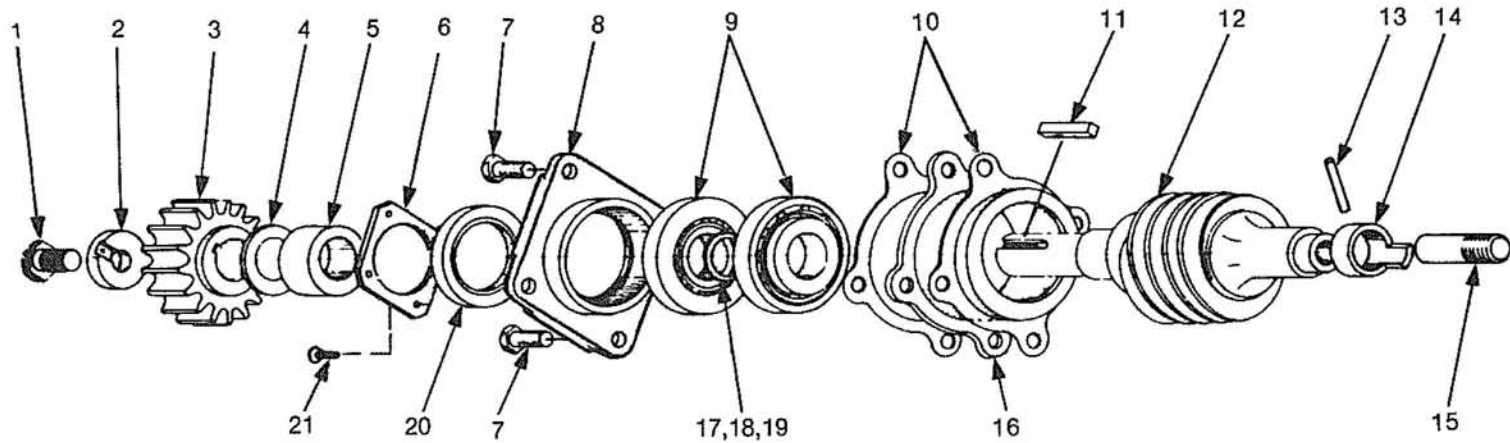

FIG. 4 — WORM ASSEMBLY PARTS DRAWING
RIGHT HAND WORM — INPUT SHAFT TO FRONT

WORM ASSEMBLY PARTS LIST
FIG. 4

ITEM	PART NAME	PART NO.	QTY
1	Bolt	250-B-79	1
2	Washer	119-E-66	1
3	Sprocket - Input, 17 Teeth	280-B-40	1
4	Shim	119-E-69	1 Set
5	Spacer	119-E-65	1
6	Plate, Retainer	150-675	1
7	Screw, Cap Hex Hd 1/2-20 UNF x 1-1/2	133-E-17	4
8	Retainer, Bearing	239-B-29	1
9	Bearing, Cone	53176	2
	Bearing, Cup	53387	2
10	Shim, Bearing Cage	109-E-59	1 Set
11	Key	127-S-49	1
12	Worm Assembly, Right Hand	224-A-100A	1
13	Pin	158-S-3	1
14	Sleeve, Stop (7/8 Worm Brake Nut)	158-S-4	1
	Sleeve, Stop (11/16 Worm Brake Nut)	125-E-15	*
15	Stud (7/8 Worm Brake Nut)	152-S-51	1
	Stud (11/16 Worm Brake Nut)	152-S-51-A	*
16	Sleeve, Bearing	239-B-18	1
17	Shim .015" Thk	125-E-24	1
18	Shim .187" Thk	125-E-23	1
19	Shim .020" Thk	110-E-66	1
20	Seal, Oil	24986	1
21	Screw, Flat Head 10-32 UNF x 5/8	Com'l	4

Note:

* Obsolete - See Note on Page 10

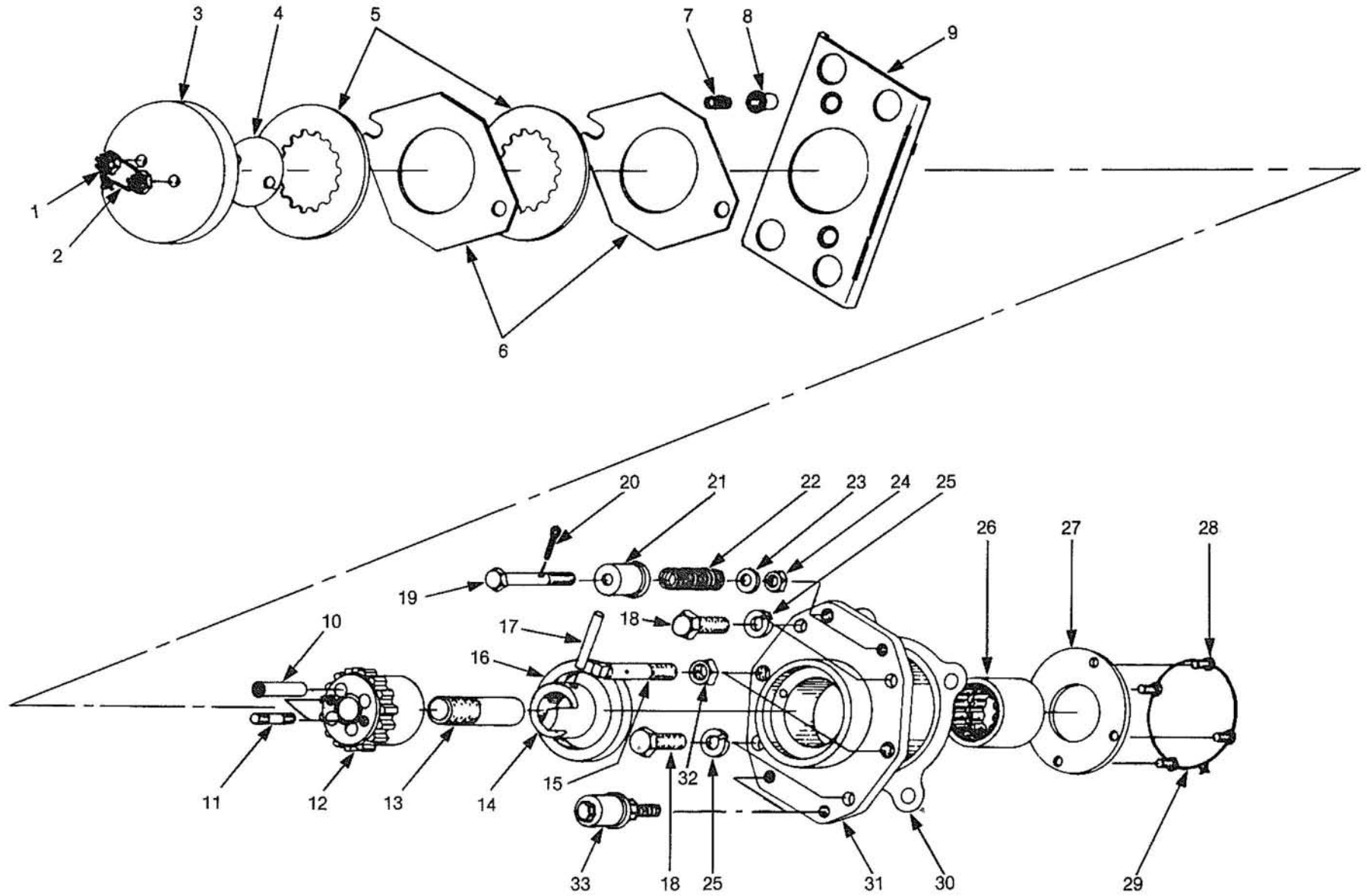

FIG. 5 — SAFETY BRAKE ASSEMBLY PARTS DRAWING

RIGHT HAND WORM

SAFETY BRAKE ASSEMBLY PARTS LIST
FIG. 5

ITEM	PART NAME	PART NO.	QTY	ITEM	PART NAME	PART NO.	QTY
1	Nut, Castle 3/8-24 UNF	Com'l	2	17	Pin (7/8 Worm Brake Nut)	158-S-3	1
2	Wire, #17 x 5' Lg	Com'l	1		Pin (11/16 Worm Brake Nut)	125-E-16	*
3	Disc, Brake (7/8 Worm Brake Nut)	156-S-100	1	18	Screw, Cap, Hex Hd 1/2-20 x 1-1/2	Com'l	4
	Disc, Brake (11/16 Worm Brake Nut)	115-E-55	*	19	Bolt	115-E-53	4†
4	Gasket (7/8 Worm Brake Nut)	158-S-1	1	20	Pin, Cotter 3/32 x 3/4 Lg	Com'l	4†
	Gasket (11/16 Worm Brake Nut)	119-E-57	1	21	Thimble Spring Outer	115-E-58	4†
5	Lining, Brake	134-S-42	2	22	Spring	114-E-10	4†
6	Plate, Brake	283-B-61	2	23	Washer, Plain 3/8 SAE Med.	Com'l	4†
7	Spring	143-S-61	2	24	Nut, Hex 3/8-24 UNF	Com'l	4†
8	Spring, Thimble	114-E-9	2	25	Washer, Lock 1/2 SAE Med.	Com'l	4
9	Plate, Pressure	283-B-60	1	26	Bearing (7/8 Worm Brake Nut)	6207-TS	1
10	Pin, Stop	141-S-44	1		Bearing (11/16 Worm Brake Nut)	16476	1
11	Stud	119-E-37	2	27	Retainer, Bearing	158-S-5	1
12	Nut, Worm Brake 7/8 RH	283-B-63A	1		Retainer, Bearing	119-E-61	*
	Nut, Worm Brake 11/16 RH or LH	283-B-63	*	28	Screw	119-E-62	4
13	Stud (7/8 Worm Brake Nut)	152-S-51	1	29	Wire #17 x 14 Lg	Com'l	1
	Stud (11/16 Worm Brake Nut)	152-S-51-A	*	30	Shim	109-E-59	1
14	Sleeve, Stop (7/8 Worm Brake Nut)	158-S-4	1	31	Cage, Bearing (7/8 Worm Brake Nut)	176-A-34	1
	Sleeve, Stop (11/16 Worm Brake Nut)	125-E-15	*		Cage, Bearing (11/16 Worm Brake Nut)	176-A-34	*
15	Stud	110-E-11	2	32	Nut, Hex 1/2-20 UNF	Com'l	2
16	Seal, Oil (7/8 Worm Brake Nut)	62440	1	33	Thimble Kit	K115-E-58-A	4
	Seal, Oil (11/16 Worm Brake Nut)	19969	1				

Note:

* 11/16 RH or LH Worm Brake Nut is obsolete.
When ordering this part or related parts, all
Winches must be converted to 7/8 RH Worm
Brake Nut with related parts

† Items available as a kit. See item 33

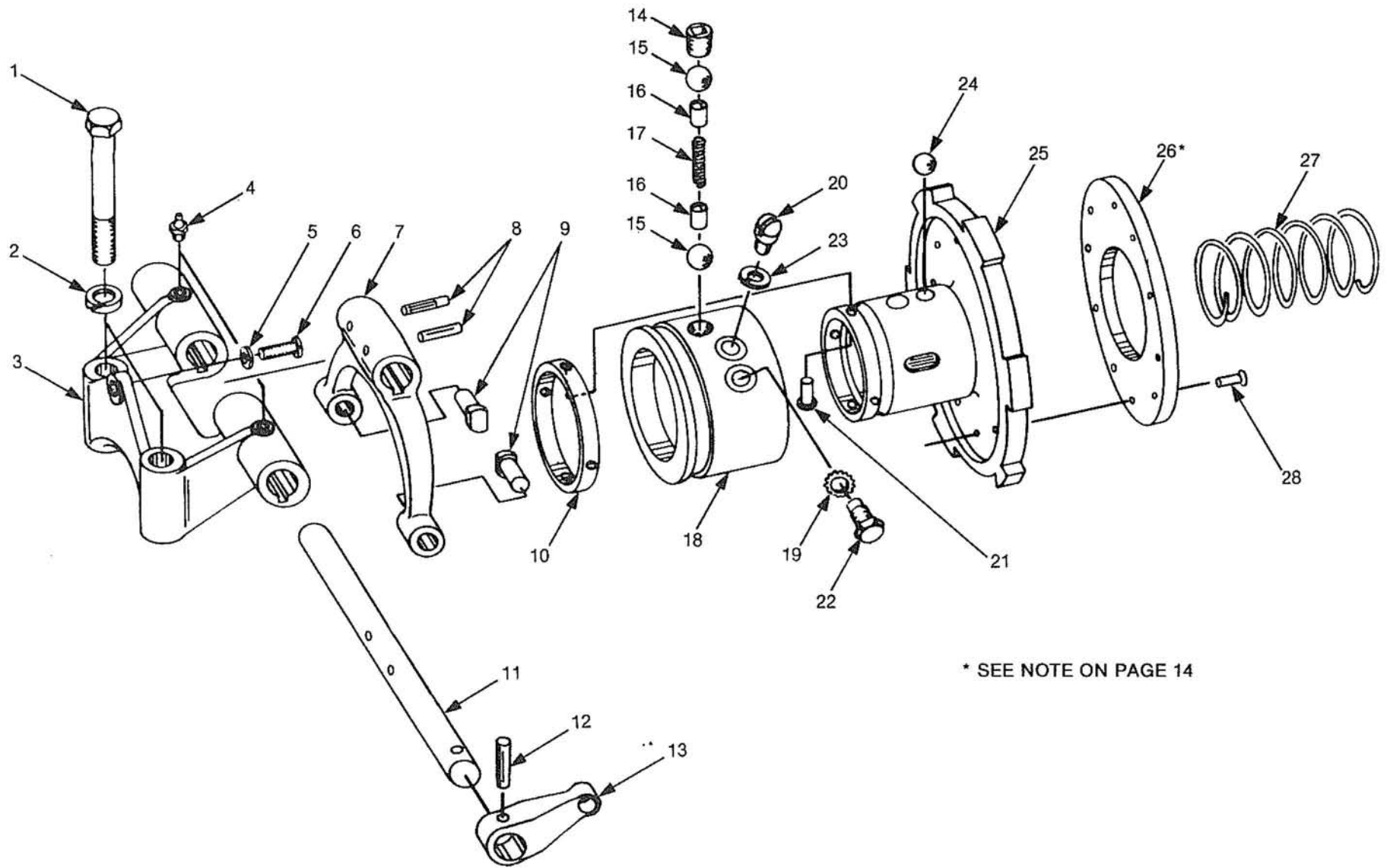

* SEE NOTE ON PAGE 14

FIG. 6 — CLUTCH AND DISC BRAKE ASSEMBLY PARTS DRAWING

216-A-98

CLUTCH & DISC BRAKE ASSEMBLY PARTS LIST
FIG. 6

ITEM	PART NAME	PART NO.	QTY.
1	Screw, Cap, Hex Hd 5/8-18 UNF x 4-1/2	Com'l	2
2	Washer, Lock 5/8 SAE Med.	Com'l	2
3	Bracket, Clutch Shaft	216-A-97W	1
4	Fitting, Lubrication	5030	2
5	Washer, Lock 3/8 SAE Med.	Com'l	1
6	Screw, Cap, Hex Hd 3/8-24 UNF x 1	Com'l	1
7	Fork, Clutch Operating	230-1533	1
8	Pin, Spring 1/4 x 1-1/2	Com'l	2
9	Pin	123-E-44	2
10	Ring, Stop	123-E-41	1
11	Shaft, Clutch	230-1534	1
12	Pin, Spring 5/16 x 1-3/4	Com'l	1
13	Lever, Clutch Yoke Shaft	127-S-18	1
14	Plug, Pipe, Countersink 1/2	Com'l	1
15	Ball, 11/16 Dia.	Com'l	2
16	Detent	123-E-42	2
17	Spring, Detent	123-E-61	1
18	Sleeve, Detent	1H171	1
19	Washer, Lock, Serrated 1/2 I.D.	1124	1
20	Screw, Detent Sleeve	123-E-60	1
21	Pin, Spring 1/4 x 5/8	Com'l	1
22	Screw, Cap, Hex Hd 1/2-20 UNF x 5/8	Com'l	1
23	Washer, Lock 1/2 SAE Med.	Com'l	1
24	Ball, 17/32 Dia.	Com'l	2
25	Plate, Clutch	239-B-66	1
26	Lining, Brake	239-B-60	1
27	Spring	123-E-43	1
28	Rivet 3/16 x 3/4	Com'l	10

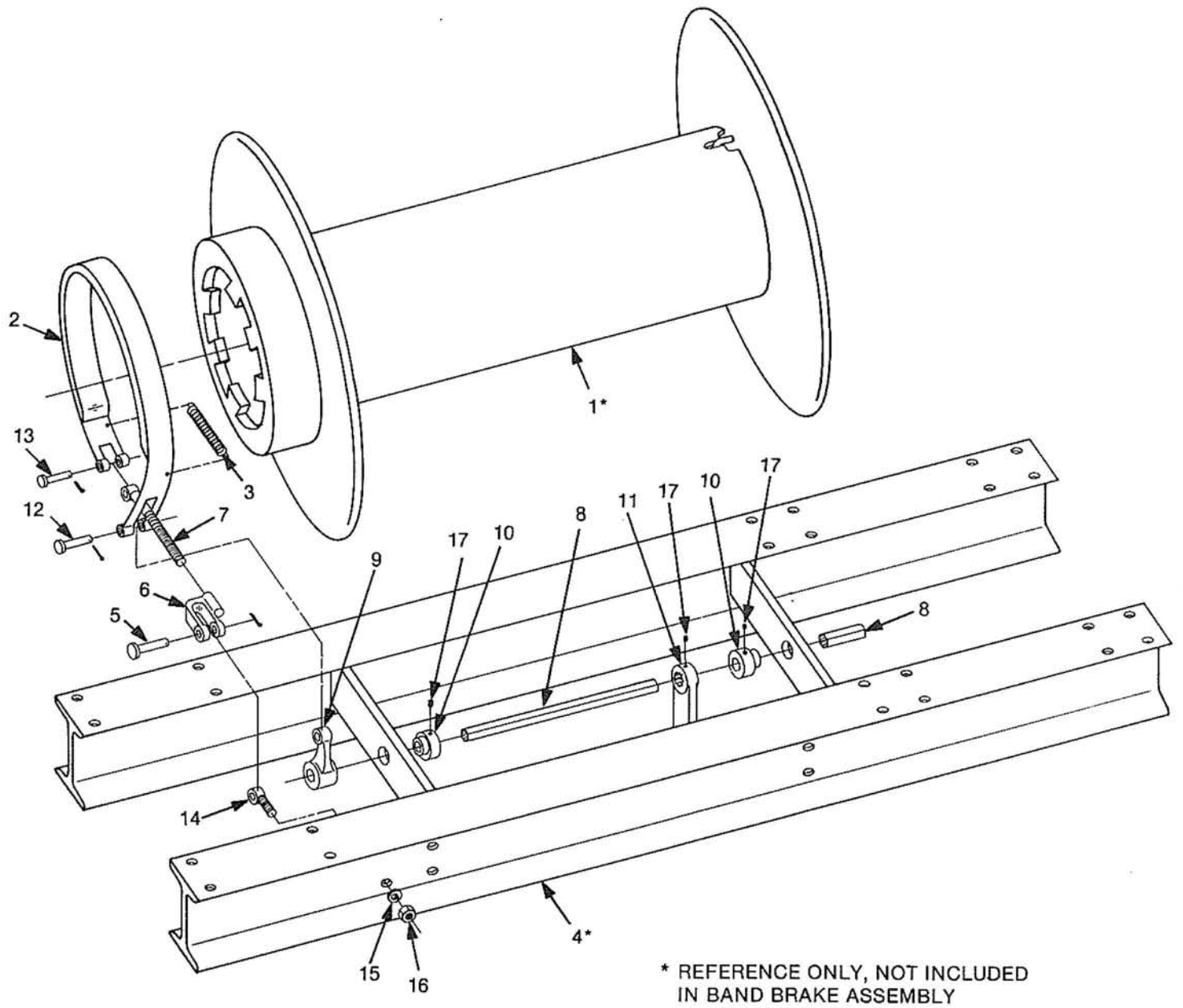

FIG. 7 — BAND BRAKE ASSEMBLY PARTS DRAWING

230-1826

BAND BRAKE ASSEMBLY PARTS LIST
FIG. 7

ITEM	PART NAME	PART NO.	QTY
1	Drum Assembly		
	UG-22	230-1535A-2	1
	UG-28	230-1535A-3	1
2	Band Assembly	230-1771	1
3	Spring	070-079	1
4	Frame		
	UG-22	230-1528-2	1
	UG-28	230-1528-3	1
5	Pin With Cotter	230-1776	1
6	Yoke End, Offset	230-1773	1
7	Rod, Eye	230-1774	1
8	Shaft, Hex	230-1827	1
9	Lever	230-33	1
10	Collar, Stop	230-32	2
11	Lever	230-60W	1
12	Pin With Cotter	230-1777	1
13	Pin With Cotter	230-1793	1
14	Rod End	151-E-50	1
15	Washer, Lock 1/2 SAE Med.	Com'l	1
16	Nut, Hex 1/2-20 UNF	Com'l	1
17	Set Screw, Cup Point 5/16-18 UNC x 3/8	Com'l	3

Note: Model UG-22 and UG-28 Winch Assemblies manufactured PRIOR to October 1, 1980 have a single control lever for clutch and disc brake.

Model UG-22 and UG-28 Winch Assemblies manufactured AFTER October 1, 1980 have separate control levers for clutch and band brake.

ADAMS EQUIPMENT



A DIVISION OF
GENERAL MACHINE PRODUCTS CO. INC.