

Battery Powered Fiber Optic Pulling Capstan

MOTOR ASSEMBLY	P/N 71490
32 IN CAPSTAN	P/N 36207
42 IN CAPSTAN	P/N 71491
GROUND STAND	P/N 71498
HITCH MOUNT STAND	P/N 71499



<https://www.gmptools.com/ecapstan/>

PART OF THE GMP
 **Powered**
LINE OF PRODUCTS

Rel.No	Date	Details	Author
01	02/23	Original issue	A Kanschak

Table of Contents

1.0	GENERAL INFORMATION	2
2.0	GENERAL SAFETY PRECAUTIONS	3
3.0	TECHNICAL SPECIFICATIONS	3
4.0	COMPONENTS INCLUDED	3
5.0	OPTIONAL ACCESSORIES	4
6.0	OVERALL DIMENSIONS	4
7.0	KEY FEATURES	5
8.0	SETUP OF PULLER AND OPERATION	5
9.0	CHARGING AND CARE OF BATTERY	11
10.0	MAINTENANCE CONSIDERATIONS & STORAGE	11

1.0 General Information

The GMP battery powered fiber optic cable puller is designed for the underground placement of fiber optic cable. It uses a rechargeable lithium Iron Phosphate Battery with an adjustable limit to the pulling tension of the capstan.

The GMP fiber optic cable puller comes complete with an electric motor, battery, controller and a hand held trigger remote control. Also the choice of a 32 or 42 in capstan.

Chose either a vehicle receiver mount with support jack for mounting to a 2" square trailer hitch or the ground stand for remote deployment

Important Precautions

Read and understand all safety instructions, warnings and procedures prior to using the GMP Battery Powered Fiber Optic Cable Puller.

 THE ECAPSTAN FIBER OPTIC CABLE PULLER IS NOT DESIGNED FOR, NOR INTENDED TO BE USED FOR THE MOVEMENT OF PEOPLE. NEVER USE THE PULLER FOR MOVING PEOPLE.

 THE ECAPSTAN FIBER OPTIC CABLE PULLER IS NOT DESIGNED FOR, NOR INTENDED TO BE USED TO PULL CABLE AERIALY. NEVER USE THE PULLER TO INSTALL CABLE AERIALY.

2.0 General Safety Precautions

1. Maintain complete coordination with other members of the crew, giving them clear instructions by hand signal or reliable radio communication.
2. As much as possible, do not stand where there is the danger of being struck by the pulling rope or cable if it should fail or snag.
3. When working around the cable puller, do not wear loose fitting clothing that may become entangled with the capstan and cause possible serious injury.
4. Keep hands safely away from capstan to prevent from getting caught or pinched.

3.0 Technical Specifications

Max Pulling Load: 900 lbs. (3558 N)@ 100lb setpoints

Max Pulling Speed: 300 feet/minute (76m/min)

Battery Life Max Pull: 8500' @ 600 lbs. & 175 feet/minute

Battery Type: LiFePO4 **Battery Size:** 48V, 40Ah

Charge Time: 8hr

4.0 Components Included with the eCapstan



MOTOR ASSEMBLY
P/N 71490

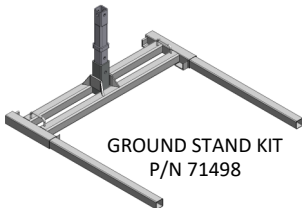

GROUND STAND KIT
P/N 71498

PICK ONE TYPE OF STAND

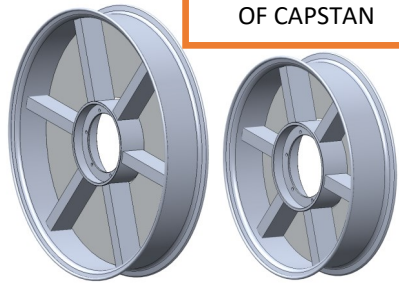

42 IN CAPSTAN
P/N 71491

32 IN CAPSTAN
P/N 36207

PICK ONE SIZE
OF CAPSTAN



HITCH MOUNT STAND KIT
P/N 71499

5.0 Optional Accessories

40 Ah battery Pack- PN 71492

Trigger controller with cord and plug- PN 71493

eCapstan power cord- PN 71494

Battery Charger- PN 71495

Capstan mounting kit- PN 35576

6.0 Overall Dimensions

42" CAPSTAN

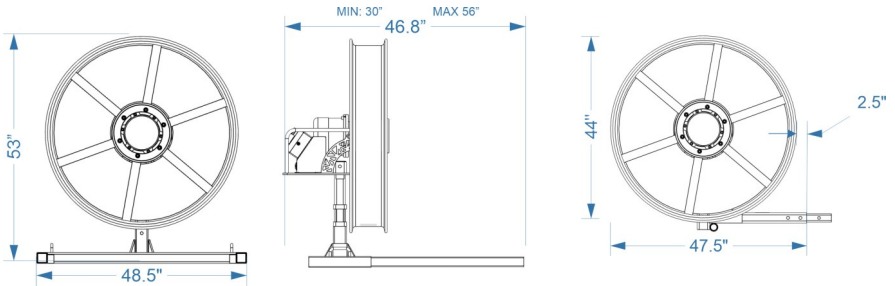

32" CAPSTAN

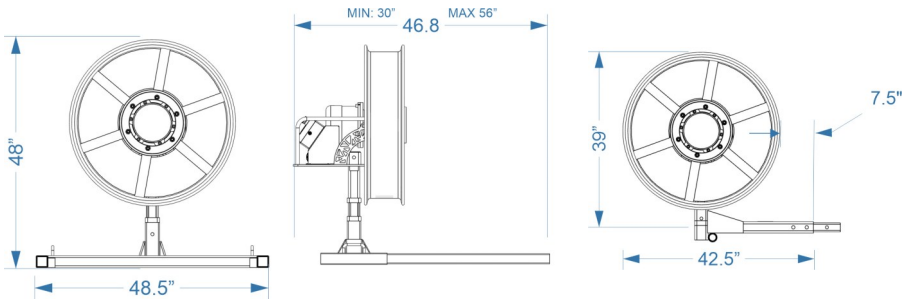

7.0 Key Features

- 15,000 ft of cable pulling on a single battery charge*
- QUIET operation improves jobsite communication and safety
- NO engine, NO emissions
- Adjustable pulling force and speed
- Electronically controlled pulling setpoints from 0-800+ lbs
- Single Person Operation
- Data recording of pull force during operation
- Hitch mount or ground stand capable
- Use 32" or 42" capstan
- Quick push button operation to set capstan diameter, max pulling force, and pulling speed
- Uses safe LiFePO4 technology
- Battery life well over 2000 full charging cycles (5+ years)

*Estimated based on average pull and average speed, exact distance per charge may vary

8.0 Setup of Puller

Use caution when lifting eCapstan cable puller. Use only proper equipment and manpower. Improper lifting could result in injury or property damage.

Place puller stand on ground over pull box or manhole. Align the puller stand so the extension legs will straddle the pull box or manhole. Install the extension legs into the ends of the stand. Verify that extension legs straddle the pull box or manhole as shown. See fig. 1.

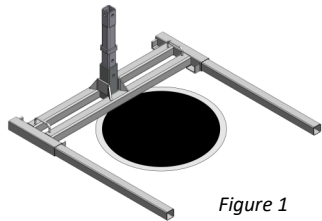
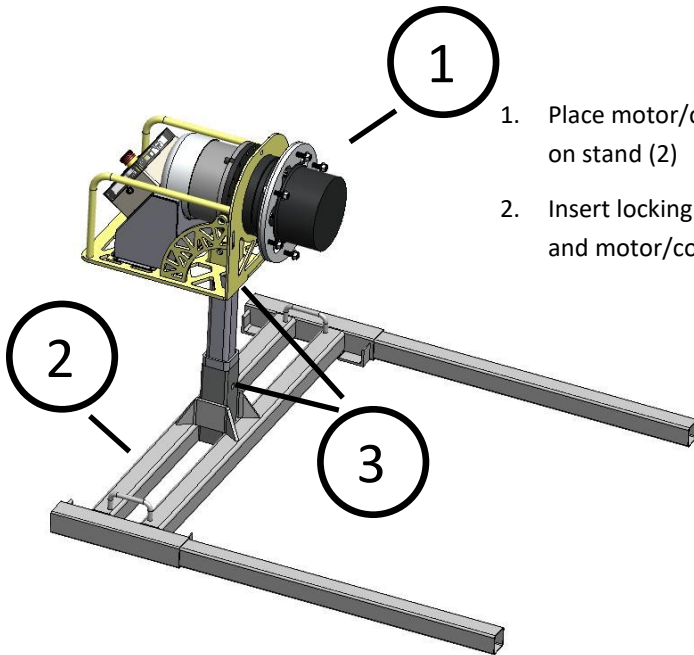

Figure 1

eCapstan Battery Powered Fiber Optic Cable Puller Operation



1. Place motor/control (1) unit on stand (2)
2. Insert locking pins (3) in stand and motor/control unit



Mount capstan to motor/control. Tighten the nuts snugly.

Ensure that the gearbox support is removed before use.

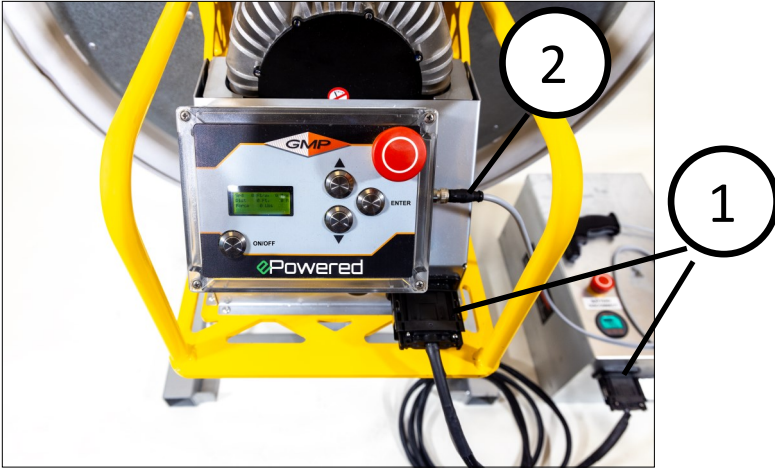

1. Plug in the power to the battery and the control/ motor unit (1).
2. Plug in the remote (2).

Powering up the eCapstan

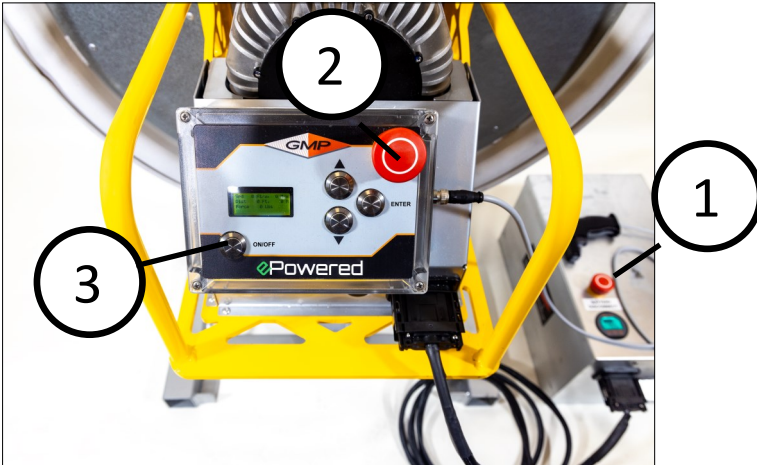

1. Ensure emergency switch on battery box is on (1)
2. Ensure emergency switch on controller is on (2)
3. Push the On/Off switch. Display will light up. (3)

eCapstan Battery Powered Fiber Optic Cable Puller Operation

Position puller over manhole as show

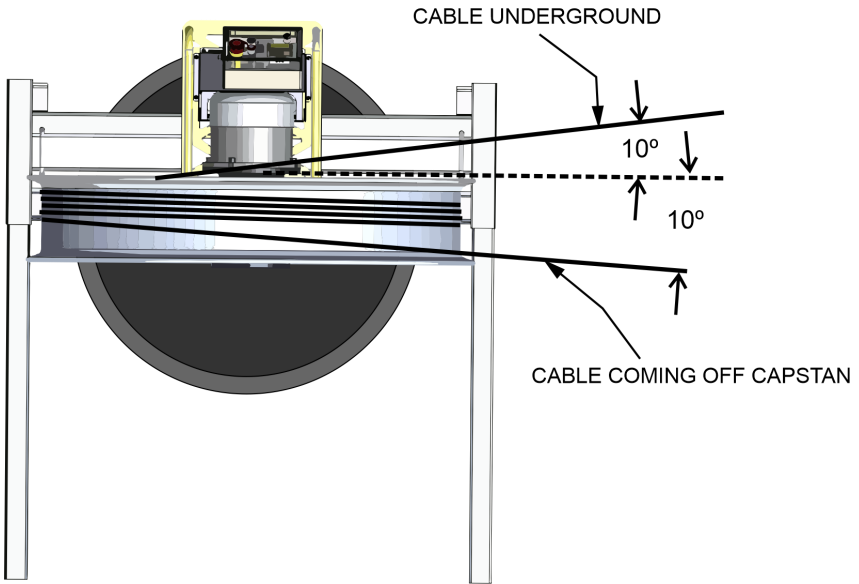

Typical Field Setup



When transporting, please attach gearbox support bracket.

When lifting the motor on and off the stand, use a group lift method. Unit weight is 180 lbs. (81Kg)



Setting Up The eCapstans Operational Parameters

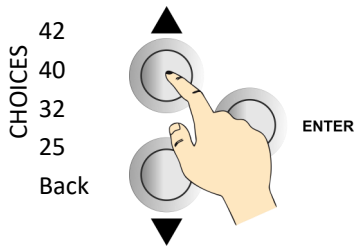

Scroll: UP/DOWN Buttons
Enter: Set

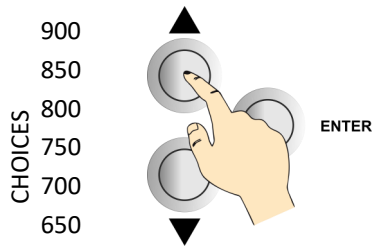
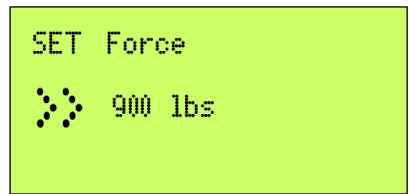

Scroll: UP/DOWN Buttons
Enter: Set

Note: on "power up" the force will default to the last selected value.

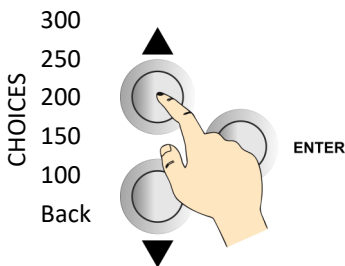
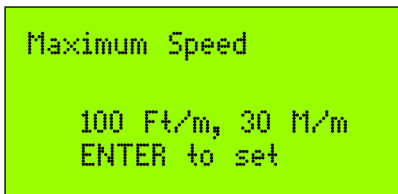

Scroll: UP/DOWN Buttons
Enter: Set

eCapstan Battery Powered Fiber Optic Cable Puller Operation

```
Spd    0 Ft/m, 0 M/m
Dist   0 Ft    0 M
Force  0 Lbs
```

Operational Screen

Note: Measured speed and distance will generally be larger than the actual, due to the nature of the operation of a capstan.

Distance Reset: From main screen, press and hold the up/down buttons together or cycle power.

```
Over Allowed Force
```

```
Press ENTER to clear
fault and continue.
```

What this means: The calculated force exceeds the set force.

Release the trigger on the control and press enter to resume operation. Maximum force can be reselected if

```
Over Current
```

```
Press ENTER to clear
fault and continue.
```

What this means: The measured battery current exceeds the safe battery output. This could be caused by sudden increase in load at high speeds.

Ensure that the cable is not snagged or restricted and pull at a slower speed.

9.0 Charging and Care of Battery

- Charge only above 32 degree F.
- LiFePO4 batteries can be continually discharged to 100% DOD and there is no long-term effect. However, we recommend you only discharge down to 80% to maintain battery life.
- Only use the battery charger provided by the manufacturer or recommended in the user manual. Using non-recommended chargers may cause improper charging and damage the battery's capacity.
- LiFePO4 batteries are designed for opportunity charging. This means that you should charge the battery whenever possible, in shallow cycles. Shallow cycle charging is better than rapid charging or deep cycle charging, as fast charging can reduce the cycle life of an LFP battery pack.

When to Charge your LiFePO4 Battery

If LiFePO4 batteries are not fully discharged, they do not need to be charged after each use. LiFePO4 batteries do not get damaged when left in a partial state of charge (PSOC). You can charge your LiFePO4 batteries after each use or when they have been discharged up to 80% (20% SOC). If the BMS disconnects the battery due to low voltage, at 100% depth of discharge, remove the load to reconnect the battery circuit and charge immediately. Please note that we recommend storing batteries at 50% state of charge (SOC).

Operating Temperature

Lithium Iron Phosphate batteries generate a fraction of the heat of other lithium chemistries making them very safe. LiFePO₄ batteries can safely operate between -4°F to 131°F (-20°C to 55°C).

How are LiFePO₄ batteries affected by temperature?

At low temperatures, the performance of a LiFePO₄ battery may be reduced. The battery may not be able to hold as much charge and may have a lower discharge rate. However, LiFePO₄ batteries have a relatively low temperature coefficient of voltage, which means that the voltage drop is relatively small when the temperature changes, thus allowing them to operate in relatively low temperatures.

At high temperatures, the performance of a LiFePO₄ battery may also be reduced. High temperatures can cause the battery to degrade more quickly, reducing its overall lifespan. High temperatures can also increase the risk of thermal runaway, which is a condition that can occur when a battery overheats and causes a chain reaction that can lead to a fire or explosion.

To ensure the best performance and lifespan, LiFePO₄ batteries should be kept in temperatures between 68–122° F (20-50°C). It is also recommended to store them in a cool and dry place when not in use. They can handle short term temperature changes, however, prolonged exposure to extreme temperatures can cause damage.

Long Term Storage

It is strongly recommended to store lithium batteries **indoors** during cold weather. It is also recommended to store LiFePO₄ batteries at a state of charge (SOC) of approximately 50% or higher. If the battery is stored for a long time, cycle the battery at least once every six months. Do not store discharged batteries.

Storage Temperature LiFePO₄ can be stored between 23°F to 95°F (-5°C to 35°C). For storage longer than 3 months, the recommended temperature range is 32°F to 77°F (0°C to 25°C).

10.0 MAINTENANCE CONSIDERATIONS & STORAGE

Store the eCapstan above 40°F (5°C) in a protected dry space such as a garage or shed away from extreme temperature variations.

Disconnect battery before making any repairs or long term storage.

Keep all nuts, bolts and screws tight, to ensure the machine is in safe working condition.

