

GMP CR Collapsible Power Reel

PART KITS

P/N 08136

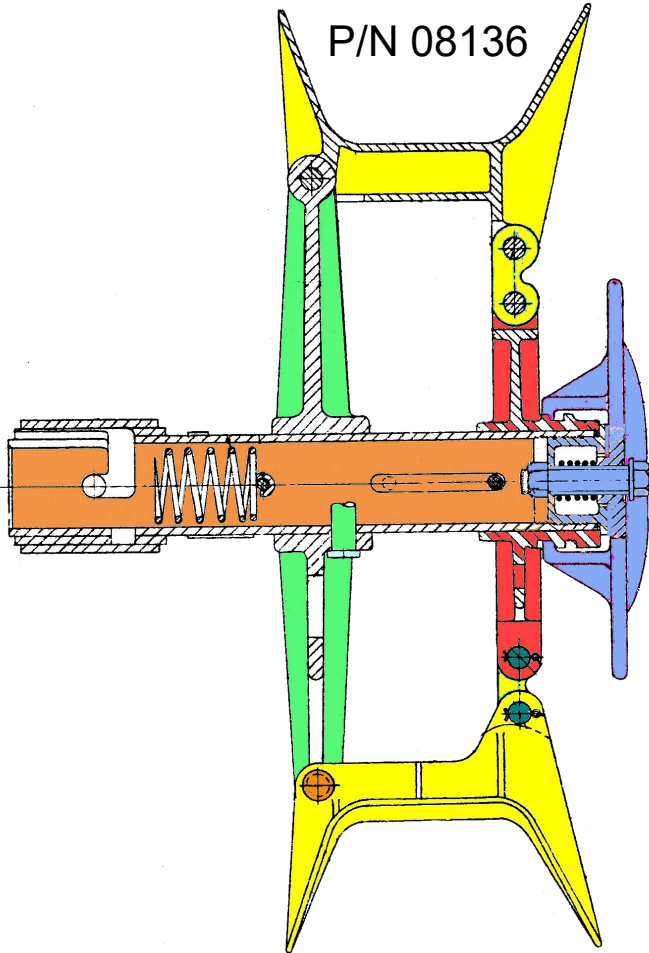

Note 1: Plug is screwed into the spindle assembly and locked by a 1/8 roll pin. This pin must be removed by driving it thru the spindle with a punch before trying to remove the plug.

Note 2: Remove plug and hold nut with wrench before trying to unscrew the bolt



Paddle and Link Kit P/N 35508

- (1) Rim Segment
- (1) Link
- (1) Pin
- (2) Pin
- (3) Locking Cotter Pin



Spindle Assy w/Spring P/N 15478

- (1) Spindle Spring
- (1) Rivet
- (1) Spindle



Sliding Spider Kit P/N 35509

- (1) Sliding Spider
- (1) Pin
- (1) Locking Cotter Pin



Fixed Spider Kit P/N 35510

- (1) Fixed Spider
- (1) Pin
- (1) Locking Cotter Pin



Handle Assy Kit P/N 15476

- (1) Handle
- (1) Shim
- (1) Plug
- (1) Bolt
- (1) Spacer Sleeve
- (1) Spring
- (1) Nut
- (1) Washer

General Machine Products Co. 3111 Old Lincoln Highway Treviso, PA 19053 USA
Tel: +1.215.357.5500 Fax: +1.215.357.6216 Email: info@GMPtools.



GMP CR Collapsible Power Reel

DIMENSIONS

P/N 08136

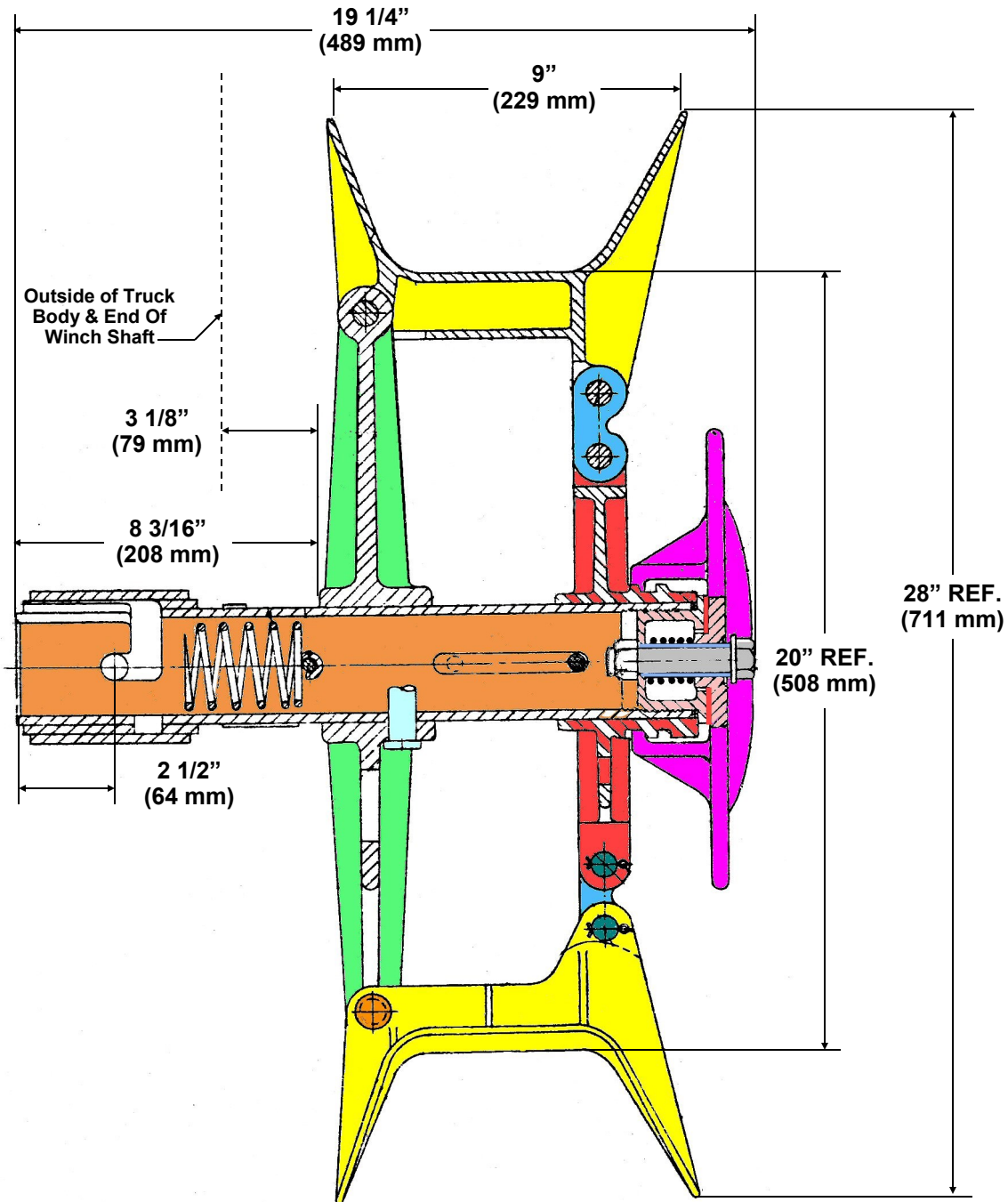

Approximate Weight 70 lbs. (32 kg)