



ACCELAIR 3 BLOWN FIBER MACHINE P/N 89601

OPERATION AND MAINTENANCE MANUAL



Copyright 2024 by General Machine Products (KT), LLC
All rights reserved. No part of this publication may be copied, reproduced or transmitted in any form whatsoever without the written permission of General Machine Products (KT), LLC



GMP • 3111 Old Lincoln Hwy • Treviso, PA 19053 • USA
TEL: +1-215-357-5500 • www.gmptools.com

January 20, 2025 USA ver 1
Manual P/N 35297

REVISION HISTORY

Rev No.	Date	Details	Author
01	09/22/22	Original Issue	C. Swallow
02	1/23/2025	Ver 1	A. Kenschak

Contents

1. SAFETY INSTRUCTIONS.....4
2. CRITICAL POINTS THAT DRAMATICALLY AFFECT THE OPERATION OF THE BLOWN FIBER BLOWING MACHINE.....8
3. GENERAL DESCRIPTION.....10
4. SPECIFICATION.....11
5. MAJOR ELEMENTS.....12
6. OPERATING PROCEDURE.....14
7. MAINTENANCE.....25
8. PROCEDURE FOR CHANGING THE BLOWING PLATES.....26
9. PROCEDURE FOR REPLACING TUBE CLAMP INSERTS AND IN-FEED GUIDES.....28
10. PROCEDURE FOR REPLACING DRIVE WHEELS.....29
11. PROCEDURE FOR REPLACING AIR SEALS.....30
12. CHECKING THE ODOMETER.....31
13. DETERMINING MAXIMUM TORQUE SETTING.....32
14. PROCEDURE FOR CHANGING DISPLAY LANGUAGE.....33
15. TROUBLESHOOTING GUIDE.....34
16. MONTHLY SERVICE – CHECK LIST.....35
17. CHANGEABLE PARTS AND ACCESSORIES36
18. SPARES.....38

GMP Limited Warranty can be found at <http://www.gmptools.com/warranty/>

1. SAFETY INSTRUCTIONS

THIS EQUIPMENT SHOULD BE USED ONLY BY PERSONNEL WHO HAVE BEEN GIVEN THE APPROPRIATE TRAINING AND WHO ARE COMPETENT TO USE IT.

THESE INSTRUCTIONS ARE TO BE MADE AVAILABLE TO OPERATORS OF THIS EQUIPMENT AT ALL TIMES, FAILURE TO OBSERVE THESE SAFETY INSTRUCTIONS COULD RESULT IN SERIOUS PERSONAL INJURY AND/OR PROPERTY DAMAGE.

WORK AREA AND GENERAL SAFETY

- Read and understand the operation and maintenance manual supplied with this equipment. Keep it in a convenient place for future reference.
- Keep children and untrained personnel away from this equipment while in operation.
- Keep all guards and safety devices in place. Do not operate this equipment with guards removed or damaged.
- Keep hands, feet and loose clothing away from moving parts.
- Always stop the machine and isolate compressed air and electrical services to carry out servicing.
- Check machine before starting for worn or damaged parts. Check for signs of loose nuts and bolts etc.
- If machine is left unattended, ensure that unauthorized use is prevented. Never leave the machine unattended while in use.
- Consider the use of safety barriers, especially when used in public places, observe all statutory requirements for working environments.
- Beware of pinch points involved with rotating components,
- Beware of hot surfaces, machine uses compressed air.

- When operating machine always wear appropriate safety clothing, ear and eye protection, hard hat, safety shoes and leather gloves. The machine operates with compressed air at up to 220 PSI (15 Bar).
- Prior to installation ensure the tube route is connected properly.
- Beware of exposed electrical contacts. Do not touch, or allow metal objects to come into contact.
- Machine may cause additional fire hazard if involved in an existing fire due to compressed air.
- The machine must be operated on firm ground.
- Stay clear of pressurized airline and tube.
- Only use the machine for its intended purpose, to retrieve fiber blow air in the far end.
- The compressed air supply must not be allowed to enter the air chamber before the lid has been securely tightened.
- Ensure the fiber exits easily from the pan. Place the pan a sufficient distance to allow the operator time to react should the fiber become tangled.
- The cable should enter the machine in a clean and dry condition.

FAILURE TO DO SO MAY RESULT IN PERSONAL INJURY OR DAMAGE TO THE BLOWN FIBER.

If a power supply is used and the connecting plug on the power lead to the generator / (or supply) is unsuitable and requires replacement, the new plug must be correctly connected observing the color codes as below.

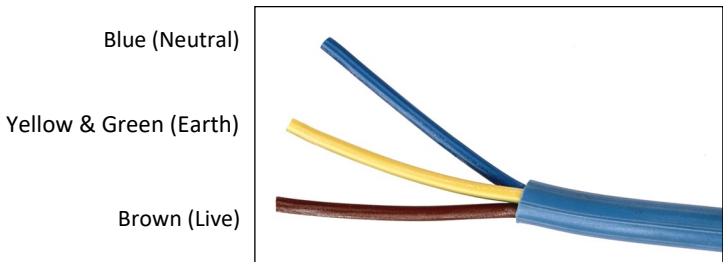

IT IS THE RESPONSIBILITY OF THE USER TO ENSURE THAT THE CONNECTIONS MEET THE ELECTRICAL REGULATIONS FOR THE RELEVANT COUNTRY.

The Accelair 3 machine itself runs off a 30V supply connected via socket. Should the connecting plug need replacement the Red wire is positive (+ve) (Pin 1) and the Black wire is negative (-ve) (Pin 3), pin 2 is unused.

GENERAL PNEUMATIC SAFETY INSTRUCTIONS

The GMP Accelair 3 Blown Fiber Blowing Machine is a pneumatic device, using pressurized air to project fiber at high velocities. Please observe the following precautions when operating the Blowing Machine:-

- Compressed air can cause flying debris. This could cause personal injury. Always wear personal protective equipment.
- Ensure no personnel are in the manhole at the far end of the fiber run. Severe personal injury may result.
- Never open the machine when pressurized.
- Only authorized, fully trained personnel should operate the air compressor.

GENERAL ELECTRICAL SAFETY INSTRUCTIONS

The machine has electronic and electrical power and control circuits. Electric shock hazards exist that could result in severe personal injury. Observe the following precautions to avoid electrical hazards:

Do not operate in water. Do not expose the machine to rain.

Do not remove cover of the power supply or the base from the Accelair 3 machine. There are no user serviceable parts inside. Refer servicing to qualified service personnel.

2. CRITICAL POINTS THAT DRAMATICALLY AFFECT THE OPERATION OF THE BLOWN FIBER BLOWING MACHINE

- Cord seals in air chamber correctly fitted to provide good sealing.
- Correct blowing plates fitted.
- Tube fully connected and pressure-tested.
- Tube connecting fittings are suitable for operating at compressor supply pressure.
- Accelair 3 lid securely tightened.
- Compressor capacity is suitable for size of tube being used.
- Fiber pan must be close to the machine, the fiber should leave the pan freely and enter the machine horizontally.
- Air chamber, drive wheel, blown fiber must be clean and free from debris, glass beads, sludge, dirt, water and lubricant.
- The fiber must be hand guided into the machine.
- Ensure the compressed air supply is not applied to the fiber until approximately 30 meters of fiber has been installed or the machine begins to slow down.
- The compressed air moisture content needs to be carefully controlled, it should be dry enough to prevent moisture forming in the tubes yet not so dry to cause a static build up – GMP Products recommend the use of an air dryer with a bypass.

DISCLAIMER

GMP takes care in the design of its products to ensure that the cable is protected during installation. Due to the variety and different methods of fiber manufacture the responsibility of checking the fiber compatibility with the equipment lies with the operator. Therefore, GMP cannot accept liability for any damage to the fiber.

3. GENERAL DESCRIPTION



The Accelair 3 Fiber Blowing Machine has been developed to provide a simple to use and reliable fiber blowing solution. The unit is designed to fit a fiber range up to 5mm diameter, thereby providing the complete range of blown fiber installation solutions from one machine.

The Accelair 3 is a compact integrated fiber blowing machine benefiting from full automation and fiber management; sophisticated fiber protection is implemented to ensure the fiber mechanical and optical integrity is maintained. The machine only requires a single 30V D.C. electrical supply and compressed air to operate.

GMP has designed a range of accessories aimed at providing the complete solution to blown fiber installation.

4. SPECIFICATION

Fiber Compatibility:	Up to 1.6mm with buckle, up to 5mm without buckle detection
Blowing Speed:	Manual control up to: 0-328 ft./min (0-100m/min) without buckle detection 0-165 ft./min (0-50m/min) with buckle detection
Compatible Tubes:	3mm to 12mm
Automation:	In buckle mode machine is self-regulating
Air Supply:	15 Bar max working pressure complete with suitable air conditioning (drying)
Electrical Supply:	Universal power supply (supplied as standard): 85-265V AC 50/60Hz input, 30V DC 5A output. Battery pack and vehicle adapter available upon request.
Control:	Remote user interface with backlit screen provides all necessary information; including current distance, speed, torque setting and fiber status. Control interface supported languages: English, French, German, Spanish, Portuguese and Italian.
Machine size:	H: 6.5" (166 mm) D: 7.2" (184 mm) L: 4.7" (120 mm) Weight: 6.6 lbs. (3kg.)
Case size:	H: 8.7" (220 mm) D: 18.9" (480 mm) L: 16.9" (430 mm) Weight (case and unit): 26.5 lbs. (12kg)
Environment:	0°C to +50°C (Usage) -10°C to +70°C (Storage)

5. MAJOR ELEMENTS

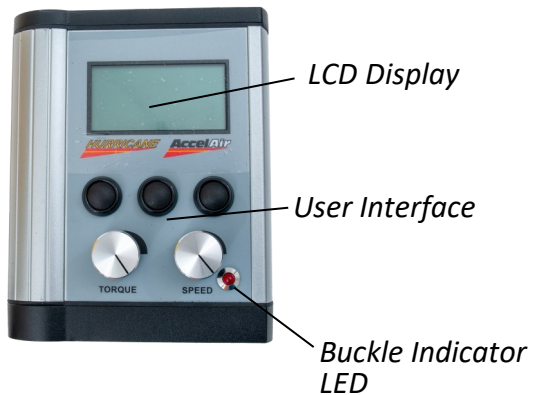
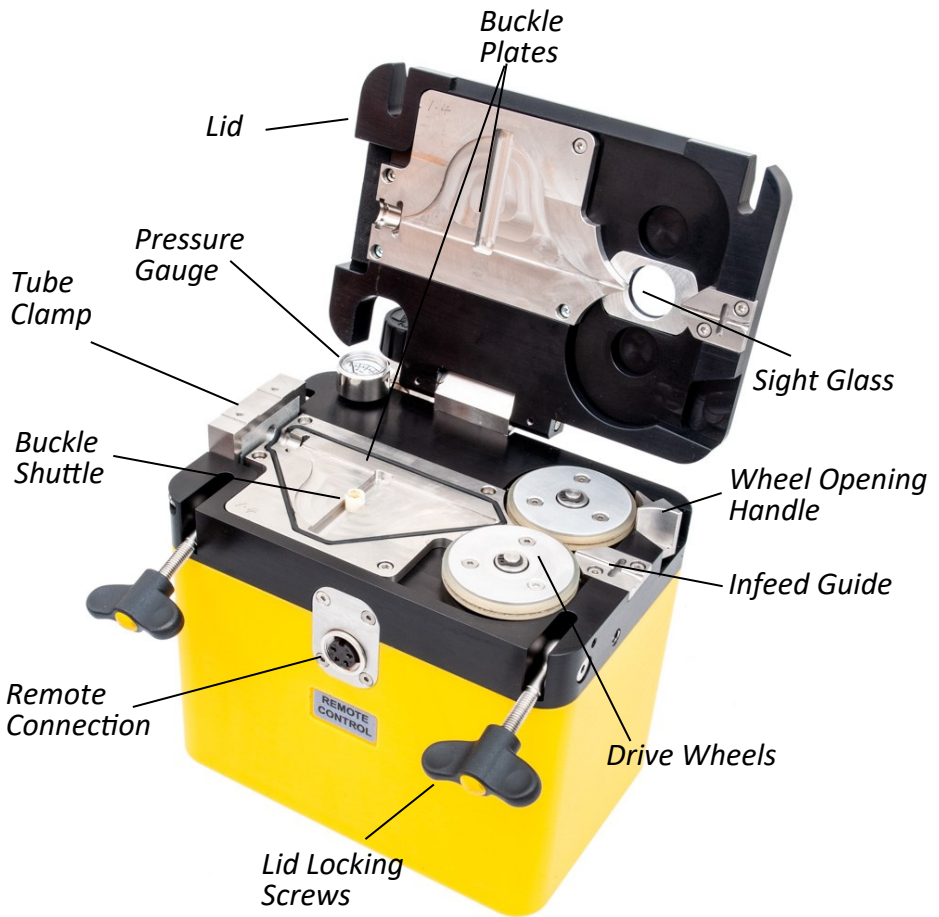

Lid Locking
Screws

Air Control Valve

Air Connection

30V Connection

Tools/Accessories

Universal AC
Power Supply

Accelair 3

Remote Unit

Included with the Accelair is a removable shoulder strap for added mobility when working in multiple locations.

6. OPERATING PROCEDURE

IT IS IMPERATIVE THAT ALL PERSONS USING, OPERATING OR MAINTAINING THIS FIBER BLOWING MACHINE:

- HAVE RECEIVED COMPREHENSIVE TRAINING IN THE USE OF THIS MACHINE
- ARE COMPETENT TO USE IT
- AUTHORIZED TO USE IT
- HAVE READ AND UNDERSTOOD THIS MANUAL

GMP CANNOT BE HELD RESPONSIBLE FOR MISUSE OF THIS EQUIPMENT.

SETTING UP THE TUBE AND FIBER

To begin an installation first we must connect the tube and fit the fiber through the machine. A selection of changeable parts are available to suit any combination of tube and fiber. Please consult sections 8, 9 and 10 for the procedures to fit these changeable parts and section 16 for a list of available parts.

It is beneficial and recommended to install a fiber blowing bead onto the end of the fiber. Place the bead over the end of the fiber and use a small set of pliers to gently crimp it in place. Try to deform the bead as little as possible while holding it in place.



8. PROCEDURE FOR CHANGING THE BLOWING PLATES

The Accelair 3 uses two types of blowing plates. One type is for use in conjunction with the buckle functionality and one without. The buckle plates use (4) M3 cap screws each to retain them into the machine; the non-buckle plates use (3) each. The supplied 2.5mm Allen wrench will be required for removal.

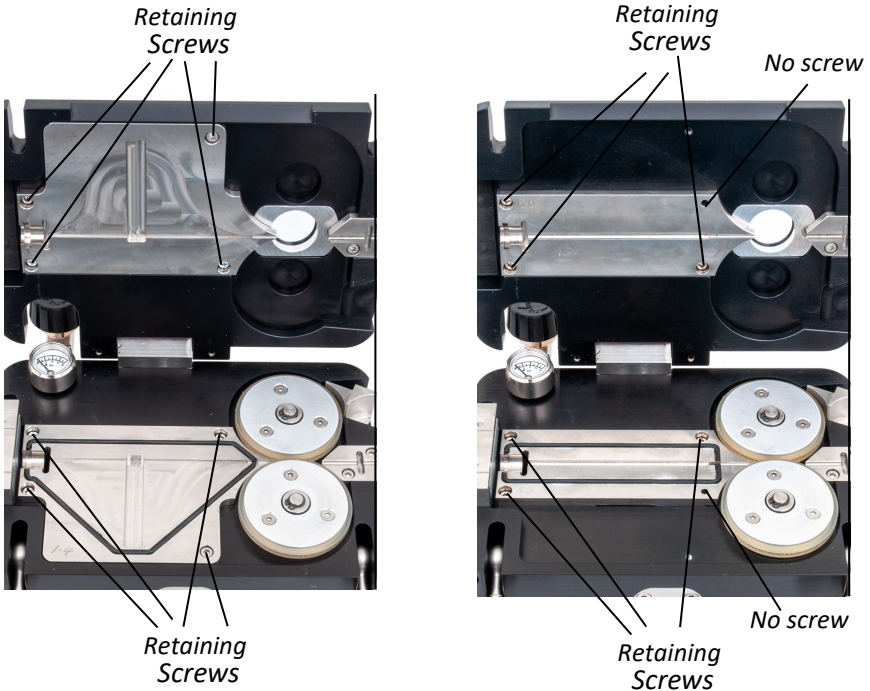

- Remove all retaining screws and lift the plates out of the machine.
- Inspect the condition of the air seal beneath the lower plate and replace if necessary (photo overleaf).
- Replace plates of suitable size into the machine and tighten the retaining screws firmly but take care not to damage the aluminium threads.

Place the tube seal over the end of the tube and insert into the machine as shown with the tube flush up to the air

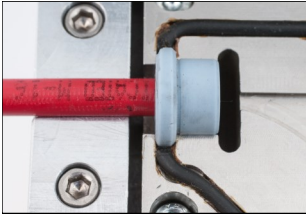

inlet and the seal in the groove. Do not allow the tube to protrude into the air inlet as this will restrict air flow and performance.

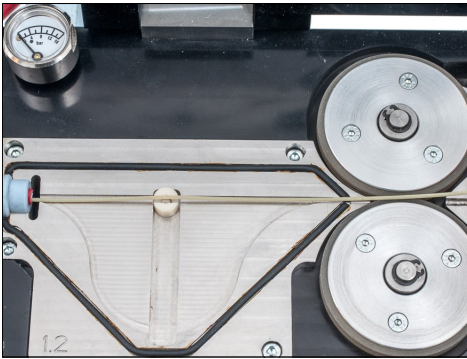
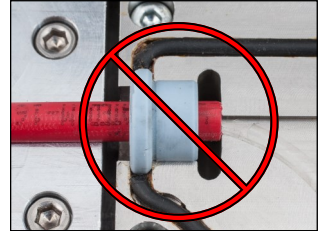

Close the tube clamp by pressing downwards; a plunger will hold it in place. Insert the end of the fiber into the tube and position it through the slot in the buckle shuttle.

Open the drive wheels as shown and place the fiber in the grooves on the buckle plate and infeed guide.

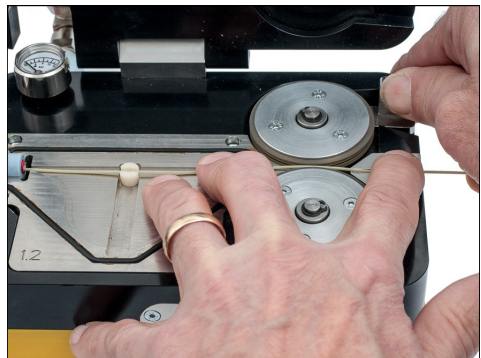



The wheels are sprung and will automatically close and grip the cable once the handle is released. Ensure the fiber runs smoothly through the machine and is placed in all grooves as shown.

Carefully close the lid, ensuring the fiber is not caught or crushed. Tighten the thumb screws to seal the lid.



NEVER OPEN THE LID OF THE MACHINE WHEN IT IS UNDER PRESSURE, SERIOUS INJURY MAY OCCUR DUE TO ITEMS EXPELLED AT HIGH VELOCITY.



5mm

GMP recommends the use of a stop end at the end of the tube route to arrest the fiber at the end of the installation.

Adapters for 4 and 3mm microduct

4mm

3mm



FIBER INSTALLATION

Insure that the remote control and the power supply is connected to the unit before plugging into the power source. After supplying power, the LCD panel on the remote unit should power up with the following display.

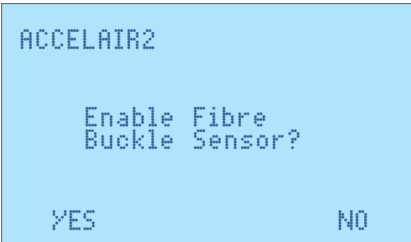

Select the option by pressing the relevant blue button under either YES or NO depending on the type of installation you wish to carry out and the plates fitted to the machine.

The buckle sensor utilizes plates with the buckle shuttle - this can be seen in the photo at the top of the previous page. Should the wrong selection be made this can be altered in the menu system, this is detailed later in this section.

Once the selection is made, a confirmation screen is briefly displayed followed by one of the screens below:

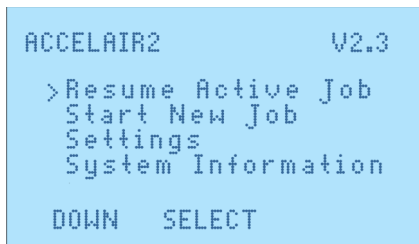
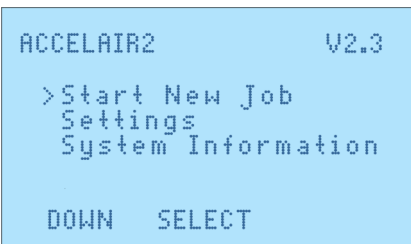

If a job has not been finished then it will remain active in memory and the screen on the right will be visible. It is then possible to either resume that job or start a new job. The blue buttons allow navigation through the menus and the functions of these buttons are displayed on the screen. Starting a new job will present you with the following display.



The two dials control the torque setting and speed. Adjustment of the torque setting is only relevant when installing fiber with the buckle functionality disabled. The torque should be set to a minimum value of 20% when buckle functionality is enabled to ensure proper operation.

This message will be displayed if the buckle mode is selected and the shuttle cannot be detected. This is either because the fiber is buckled in the machine or because you are attempting to install with a straight plate but have not disabled the buckle functionality.

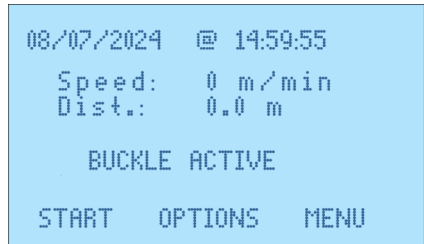

Should the incorrect buckle mode be selected at power up select 'MENU' if not already there and then select 'SETTINGS'. When on the buckle sensor option press 'Change' to alter this function. You can then return to the menu and resume active job; the error will now have disappeared.

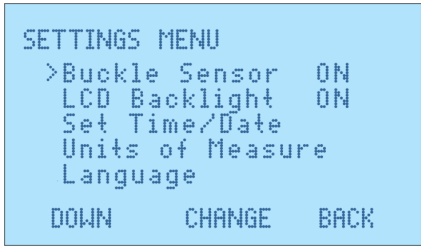

To check the buckle function and to allow a viewing point for the fiber we suggest a small length of tube with a clear connector be used in the machine first. Moving the fiber in and out should be possible; the screen should display that the buckle shuttle is moving.

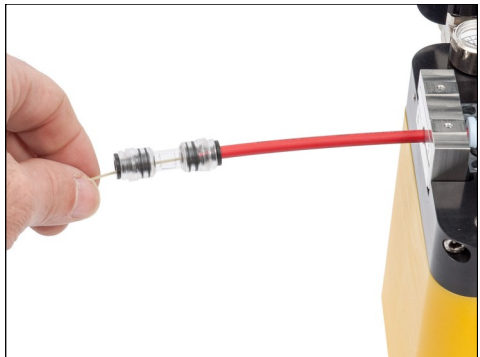

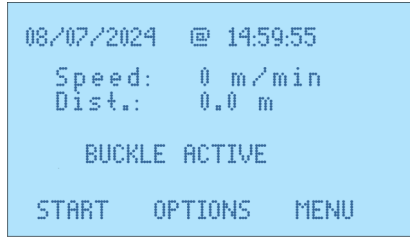
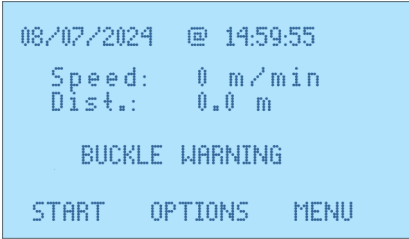

As the fiber is moved into the machine the screen will first display 'warning' and then when more fiber is fed through it will display 'active'. Eventually it will display 'error'; do not worry, this simply means the buckle shuttle has moved beyond the sensing range. In 'error' mode the machine reacts as though it were in 'active' mode.

For installing fiber with the buckle function disabled it will be necessary to perform a test to determine the maximum torque setting that can be used to ensure the fiber is not damaged. See section 13 for details on how to perform this test.

Once satisfied that all settings are correct the installation can begin.

Press start and the machine will begin the installation. It will accelerate slowly as there is a soft-start function; this is to protect the fiber from damage. Notice the distance readout increase and



also that the speed readout may not always match the input setting; this could be due to the buckle being active or a high resistance on the fiber.

The speed and torque settings can be adjusted at any time by moving the dials either clockwise or counter-clockwise. The machine will slow instantly but will accelerate slowly as previously described



After 100 - 150 feet of fiber has been installed it will be necessary, as resistance increases, to introduce airflow down the tube. Turn the knob on the needle valve as indicated to allow air into the system. This valve should provide a degree of control over the air pressure used.



A lower pressure is beneficial at first; with increasing distance the pressure should be increased to maintain installation speed. Consult the pressure gauge for your current system installation pressure.



WARNING

DO NOT EXCEED THE MAXIMUM SYSTEM PRESSURE OF 15 BAR OR OPEN THE MACHINE WHEN UNDER PRESSURE, SERIOUS INJURY MAY RESULT.

The installation of fiber should now be semi-automatic. If the buckle function is not in use then the machine will come to a stop when there is a blockage; the fiber will be undamaged as there will not be enough torque to break it. Once the machine has come to a stop, press 'stop' on the remote to prevent the machine continuing when the blockage is rectified.

If the buckle function is in use then the machine will automatically slow or stop if it comes up against a resistance. If it comes to a stop then it will reverse to straighten the fiber before continuing; it will reverse a maximum of three times before considering there to be a blockage at which point the installation will be halted.



The following display will be visible along with the red LED. It will now be necessary to investigate the cause of the blockage and remove it before attempting to continue.

Once safe to do so, open the machine and reset the buckle shuttle. The 'OK' option will then appear; pressing this takes you back to the installation screen and will allow viewing of the current installation distance. This may be needed to help

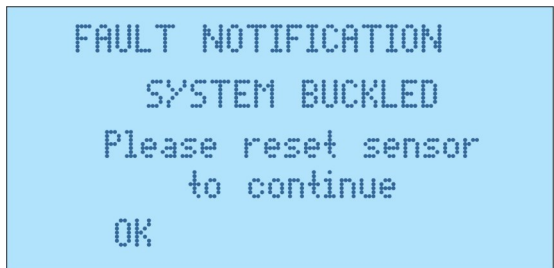

remove the blockage. Once all blockages have been removed the installation can resume to completion. When the route has been completed press 'stop', turn off the air supply and allow any pressure in the system to dissipate. You may then open the machine and retrieve the fiber.

It is advisable to finish the current job to ensure the next installation begins with the distance reset to zero. To do this select 'OPTIONS' from the installation screen followed by 'Finish Job'. You will be asked to confirm this selection.

```
08/07/2024 @ 14:59:55
Speed: 0 m/min
Dist.: 0.0 m
T: 100% S: 50 m/min
START  OPTIONS  MENU
```

```
OPTIONS
Finish Job
>Reverse Mode OFF
DOWN  CHANGE  BACK
```

```
END JOB CONFIMATION
Are you sure you want
to finish the job?
YES  NO
```

Reverse Mode

You are able to reverse the motor in order to pull fiber out of the duct . Select Option.

```
08/07/2024 @ 14:59:55
Speed: 0 m/min
Dist.: 0.0 m
T: 100% S: 50 m/min
START  OPTIONS  MENU
```

Then press 'DOWN' to scroll to the reverse option, press 'CHANGE' to activate the function and then 'BACK' to return to the installation screen. Repeat this process to turn the reverse function off.

```
OPTIONS
Finish Job
>Reverse Mode OFF
DOWN  CHANGE  BACK
```

```
08/07/2024 @ 14:59:55
Speed: 0 m/min
MOTOR IN REVERSE!
T: 46% S: 25 m/min
START  OPTIONS  MENU
```

Imperial Units

The Accelair 3 machine can display metric or imperial measurement formats as well as European and American date formats. To set your machine to the desired units navigate to the settings screen.

```
SETTINGS MENU
>Buckle Sensor  ON
  LCD Backlight  ON
  Set Time/Date
  Units of Measure
  Language
DOWN      CHANGE  BACK
```

Scroll down to 'Measurement Units' and press 'SELECT'.

```
Units of Measure
> Date          DD/MM/YY
  Live Data     METRIC
  ODO Units     METRIC
DOWN      CHANGE  BACK
```

```
Units of Measure
  Date          MM/DD/YY
  Live Data     IMPERIAL
> ODO Units     IMPERIAL
DOWN      CHANGE  BACK
```

You can now scroll down and individually change the displayed units and date format by pressing 'CHANGE'. Once the desired units and format have been set press 'BACK' to return to the settings screen. These settings will now be saved even when the machine is powered down.

7. MAINTENANCE

The GMP Blown Fiber Blowing Machine has been designed to give reliable, trouble free service over long periods. The machine requires no sophisticated maintenance procedures; simple common sense checks and precautions are all that are needed.

The main source of breakdown and/or malfunction of a machine being used outdoors is contamination by the elements, this contamination may be introduced into the machine in a number of different ways.

The most likely may be mud, dust or other contaminants carried into the machine on the fiber. However glass beads from EPFU fiber may also contaminate the machine.

The machine may be set down on a muddy surface, or be splashed by road going vehicles when it is being used by the roadside.

The machine should be returned to the manufacturers after every 150 miles (250 kilometres) use (or at intervals of 12 months) for a major service.

Store the removed plates in the bag provided and in the designated area of the carry case to avoid loss or damage.



The above figure shows the air seal beneath the lower blowing plate. This seal should sit above the surface; if it has become flattened or damaged replace to maintain a good air seal and blowing performance.

9. PROCEDURE FOR REPLACING TUBE CLAMP INSERTS AND INFEED GUIDES

Various tube clamp inserts and infeed guides are available for the Accelair 3 to allow the use of different tube and fiber sizes. Tube clamp inserts are retained using (2) M3 cap screws each and require the use of the 2.5mm Allen wrench; infeed guides are retained using (2) M3 cap screws and require the use of the 2.5mm Allen wrench.

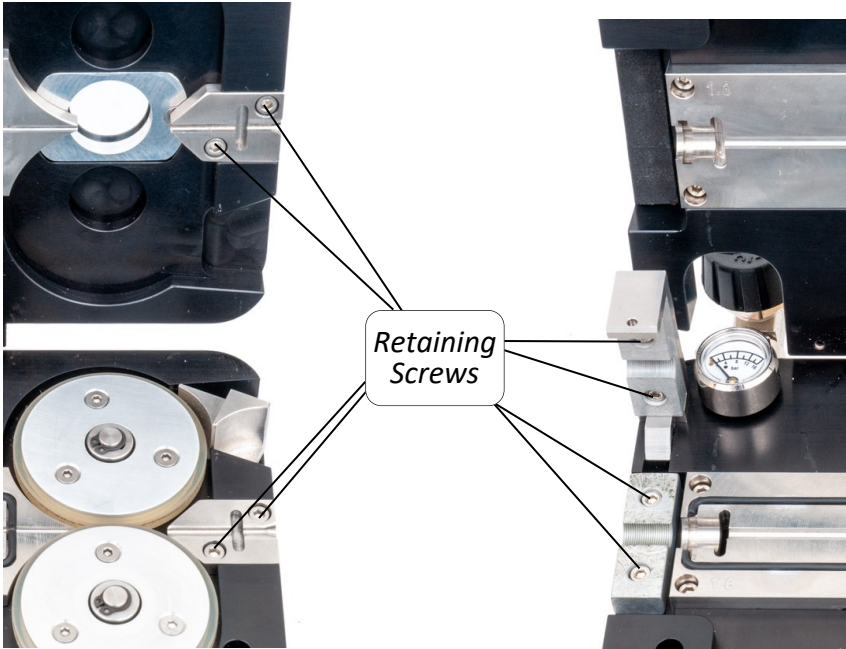

- Remove all retaining screws and remove the inserts/guides.
- Replace inserts/guides of suitable size into the machine and tighten the retaining screws firmly but take care not to damage any aluminium threads.
- Store the removed inserts/guides in the bag provided and in the designated area of the carry case to avoid loss or damage.

10. PROCEDURE FOR REPLACING DRIVE TIRES

The Accelair 3 uses replaceable silicone drive tires to provide grip to install the blown fiber. Two different sizes are available for small and large fiber. When installing a different fiber or through wear it will be necessary to replace these drive tires.



Remove all six M3 countersunk screws.



Remove the two wheel assemblies off the drive hubs

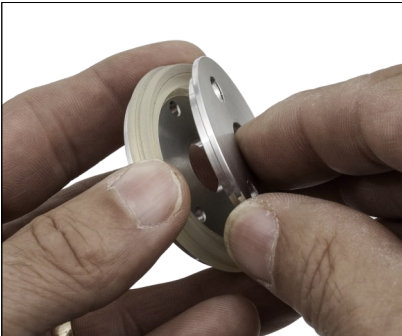

Separate the top and bottom support wheels.



Remove the old silicone tire

- Stretch a new tire over the lower wheel plate.
- Replace the top plate, being careful to line up the holes. The new tire may require slight manipulation to stretch it on to the top wheel half.
- Replace the countersunk screws; note that while tightening the screws the operator should feel the tire being slightly compressed.

ALWAYS ENSURE TIRES ARE REPLACED AS PAIRS OF THE SAME SIZE.

11. PROCEDURE FOR REPLACING AIR SEALS

All seals fitted to the Accelair 3 are 2 mm cord seal. When replacing the seal on a blowing plate it is recommended that the plate is removed from the machine.

- Remove the existing seal.
- Cut a length of 2 mm cord seal slightly longer than required – one continuous length is required.
- Apply a thin coat of 3M Rubber and Gasket Adhesive to the top of the cut sealing material
- Place the cord seal in the groove starting at the tube seal bore allowing a slight excess to protrude into the tube grip (A).
- Trim the seal to finish flush with the edge of the tube seal bore – take care not to damage the bores surface (B).

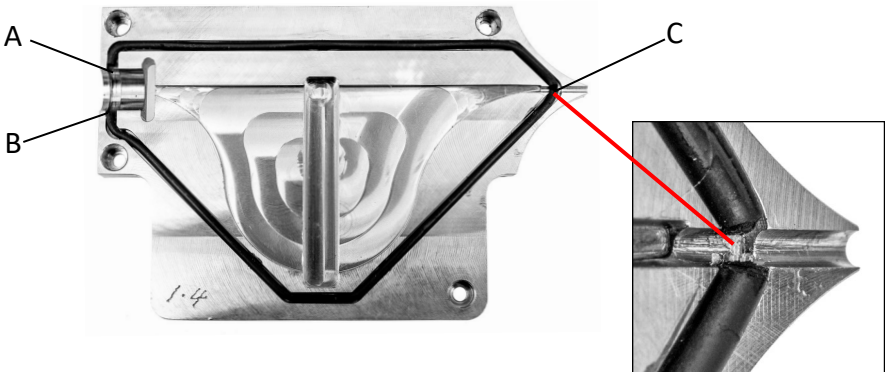

- Cut a 'V' in the seal to match the groove at the fiber entry point (C).
- Refit the plate to the Accelair 3.
- Cut a scrap length (3' will be sufficient) of the correct size blown fiber, install it into the machine and pull it back and forward through the machine with the lid fully clamped. This will ensure there is sufficient clearance in the 'V' cut in the seal to allow fiber installation.

12. CHECKING THE ODOMETER

The Accelair 3 has an odometer to indicate the total distance the machine has installed during its service life. This can be accessed via the 'System Information' page from the main menu.

```
CBS ACCELAIR2 MENU
  Resume Active Job
  Start New Job
  Settings
  > System Information

DOWN  SELECT
```

```
SYSTEM INFORMATION
ODO:    8267 m
Main:   066CFF535653
        865267193927
Remote: 066CFF485252
        714987141539
MENU
```

Also displayed will be the ID numbers for the Accelair 3 machine and the remote unit. It may be useful to log these numbers as the main and remote units are interchangeable.

Note: If you update the firmware, record the odometer distance as it will be reset to **zero** after completion.

13. DETERMINING MAXIMUM TORQUE SETTING

When performing an installation of a larger or stiffer fiber it may be necessary to use a straight set of blowing plates. To ensure the integrity of the fiber at all times during the installation it is crucial a test is performed. This test will provide the installer with the maximum torque setting for the machine such that if the fiber hits a blockage at speed, the fiber will not be damaged.

- Set the machine up as per section 6 using non-buckle plates (therefore no buckle shuttle will be present).
- Instead of attaching to the installation route use a 5m length of the same tube. Use a stop end kit to block the end of the tube.
- Set the speed to the maximum installation speed to be used.
- Set the torque to approximately 10%.
- Press 'start'. The machine will now accelerate to the speed setting.
- When the fiber hits the end stop the machine will either stop and leave the fiber undamaged or continue to install and break the fiber, in either case press 'stop' to prevent the machine from trying to continue the install. Reduce or increase the torque setting as appropriate for the outcome of the previous test and perform the test again. Through several iterations a torque setting just below the value which would break the fiber should become apparent.

14. CHANGING THE DISPLAY LANGUAGE

The Accelair 3 machine can display in several languages – English, French, German, Spanish, Portuguese and Italian. To set your machine to the desired language navigate to the settings screen.

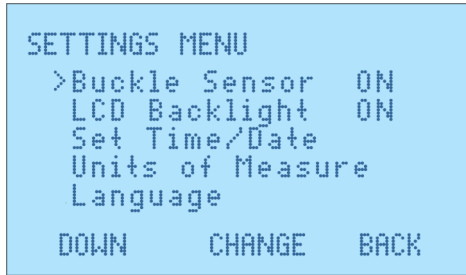

Scroll down to 'Language' and press 'SELECT' and scroll through to select the desired language. Languages selections are displayed in the current language setting (between arrows) and the native translation above.

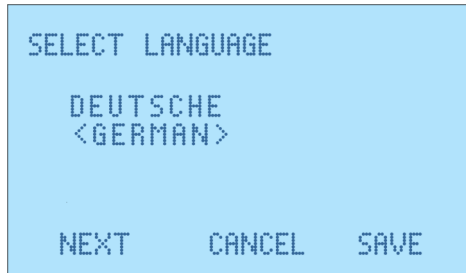

Powering up whilst holding all three blue buttons on the remote will revert the language setting to English (this will not alter any other settings or delete information).

15. TROUBLESHOOTING GUIDE

- Air loss from the Accelair 3 machine is greater than normal:
 - Ensure the correct plates are fitted for the fiber and tube being used.
 - Check air seal beneath the lower blowing plate; replace if necessary.
 - Check blowing plate seal; replace if necessary.
- Little or no air-flow is exiting the tube:
 - Check compressor output (refer to manufacture's handbook).
 - Installation route may be too complex for installation.
 - Route length is too long.
 - There may be a partial blockage in the tube.
 - The tube may be crushed somewhere along the route.
- Fiber 'rides' out from between the drive wheels:
 - Larger drive wheels may be needed for improved guidance – follow section 10 for details on changing drive wheels.
- Fiber installation speed is very slow:
 - Static build up – switch the compressor from dry air to by-pass mode (if available).
 - Moisture build up – ensure compressor is running in dry air mode or check dryer operation.
- Fiber buckles often:
 - Installation route may be too complex for installation.
 - The tube route may be damaged/blocked.
 - Increase air pressure if possible.
 - Manually slow the installation speed slightly.
- Machine won't run - error displayed
 - Check plates fitted to the machine. If non-buckle plates are being used, ensure the machine is set to non-buckle operation. See page 20

- Ensure a buckle leaf is fitted in the buckle plates and that it moves freely in the groove.
- No drive/Drive wheels slipping:
 - Smaller drive wheels may be needed for improved grip – follow section 10 for details on changing drive wheels.
 - Drive wheels may be excessively worn – install new wheels.

16. MONTHLY SERVICE – CHECK LIST

This section is included in the manual for your convenience, there follows a list of suggested checks, it is recommended that these checks be carried out on a regular basis, depending on use. Monthly checks are convenient; a few minutes can be set aside on the same day of each month to complete these simple checks.

- Check the carry case, ensure all tools and interchangeable parts are present, clean and ready for use.
- Clean the outside of the machine and remote; take care not to damage the display screen, buttons, dials or connectors.
- Inspect air and electrical connections for damage.
- Inspect drive wheels for wear; replace if necessary.
- Inspect buckle shuttle for wear; replace if necessary.
- Check quantities of consumable items such as blowing beads, and buckle shuttles.

17. CHANGEABLE PARTS AND ACCESSORIES

Stainless Fiber Buckle Plates with 5 Buckle Shuttles

P/N	Description
89440	1.0mm Buckle Plate
89441	1.2mm Buckle Plate
89442	1.4mm Buckle Plate
89443	1.5mm Buckle Plate
89657	1.6mm Buckle Plate

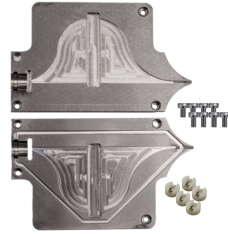

Fiber Buckle Plates Stainless

Stainless Fiber Blowing Plates

P/N	Description
89658	1.7mm Blowing Plate
89661	2.0mm Blowing Plate
89662	2.1mm Blowing Plate
89674	2.3mm Blowing Plate
89666	2.5mm Blowing Plate
89669	2.6mm Blowing Plate
89670	2.8mm Blowing Plate
89671	3.0mm Blowing Plate
89683	3.6mm Blowing Plate
89684	4.5mm Blowing Plate
89685	5.0mm Blowing Plate

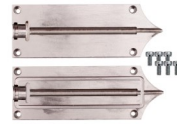

Fiber Blowing Plates Stainless

Tube Clamps and Seals includes 5 Tube Seals

P/N	Description
89491	3mm Clamp and Seals
89492	4mm Clamp and Seals
89493	5mm Clamp and Seals
89494	6mm Clamp and Seals
89495	7mm Clamp and Seals
89496	8mm Clamp and Seals
89497	8.5mm Clamp and Seals
89498	10mm Clamp and Seals
89679	12mm Clamp and Seals



Tube Clamp and Seals

Infeed Guides

P/N	Description
89478	.08 - 2.0mm
89479	2.0 - 3.0mm
89675	3.0 - 5.0mm



Infeed Guide

Spare Tires 10/pk

P/N	Description
89503	up to 2.0mm
89508	2.0 - 3.0mm
89686	3.0 - 5.0mm



Spare Lower Plate Seals 5/pk

P/N	Description
89437	Seal 5/pk



Spare Buckle Shuttle 5/pk

P/N	Description
89436	Shuttles 5/pk



Spare Tube Seals 5/pk

P/N	Description
89936	3mm
89937	4mm
89938	5mm
89939	6mm
89940	7mm
89941	8mm
89942	8.5mm
89953	10mm
	12mm



For the latest updates, please go to the website at gmptools.com

ACCESSORIES

Description	Order Code
5mm Clear Tube Connector (Pack of 5)	89710
Air Flow Meter	89703

Other sizes of clear tube connector are available. Air flow meter can be used to check route integrity. Please contact the GMP sales office to order or enquire about parts not listed; always quoting the machine type and serial number.

Air Flow Meter



5mm Clear Tube Connector (Pack of 5)

Accelair 3 Bottled Nitrogen Kit for Blown Fiber

Used with bottled nitrogen in place of a compressor for 5mm or smaller Microduct

- Quickly connects to the Accelair 3 via a quick coupling.
- Hose is 10 feet long for easy setups.
- The regulator has easy to read 2" gauges.
- The flexible hose is abrasion, weather and ozone resistant.
- Inlet connection is CGA 580.



Do Not Exceed the Hose Rating of 200 PSI.

Accelair 3 Bottled Nitrogen Kit

P/N 74080 Weight: 5 lbs. (2.3 kgs)

18. SPARES

89437 - Lower Plate Seals 5/pk



89436 Spare Buckle Shuttles 5/pk



Power Supply



89522



89524

34047 - Input Air Hose



Replacement Remote Control



90001

Remote Control (Hurricane/Accelair)

18. SPARES (continued)



33502
Wing Screw
Version 1



33814
Nylon Retaining
Washer



34796
Wing Screw
Version 2

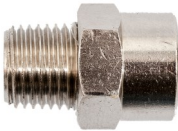

32962
Adapter



33035
Needle Valve



33039
Plug



89691
2mm Cord Seal
3 ft.



34709
Pressure Gauge



GMP • 3111 Old Lincoln Hwy • Trevose, PA 19053 • USA
TEL: +1-215-357-5500 • www.gmptools.com