



STORM MICRO FIBER BLOWING GUN
P/N 91000
OPERATION AND MAINTENANCE MANUAL



STORM

FIBER BLOWING MACHINE

Copyright 2026 by General Machine Products (KT), LLC All rights reserved. No part of this publication may be copied, reproduced or transmitted in any form whatsoever without the written permission of General Machine Products (KT), LLC



GMP • 3111 Old Lincoln Hwy • Treose, PA 19053 • USA
TEL: +1-215-357-5500 • www.gmptools.com

REVISION HISTORY

REV #	DATE	DETAILS	AUTHOR
01	01/19/26	Original Publication	L. Brown
02	04/15/26	Localization	A Konschak

Contents

1. SAFETY INSTRUCTIONS.....	4
2. CRITICAL POINTS THAT DRAMATICALLY AFFECT THE OPERATION OF THE BLOWN FIBER BLOWING MACHINE.....	8
3. GENERAL DESCRIPTION.....	10
4. SPECIFICATION.....	11
5. MAJOR ELEMENTS.....	12
6. OPERATING PROCEDURE.....	17
7. MAINTENANCE	24
8. PROCEDURE FOR REPLACING TIRES.....	25
9. TROUBLESHOOTING GUIDE.....	26
10. MONTHLY SERVICE – CHECK LIST.....	28
11. SERVICE HISTORY RECORD.....	29
12. CHANGEABLE PARTS AND ACCESSORIES.....	30

1. SAFETY INSTRUCTIONS

THIS EQUIPMENT SHOULD BE USED ONLY BY PERSONNEL WHO HAVE BEEN GIVEN THE APPROPRIATE TRAINING AND WHO ARE COMPETENT TO USE IT.

THESE INSTRUCTIONS ARE TO BE MADE AVAILABLE TO OPERATORS OF THIS EQUIPMENT AT ALL TIMES, FAILURE TO OBSERVE THESE SAFETY INSTRUCTIONS COULD RESULT IN SERIOUS PERSONAL INJURY AND/OR PROPERTY DAMAGE.

BEFORE USING ANY PART OF THIS MACHINE OR ITS ACCESSORIES, YOU MUST READ AND FULLY UNDERSTAND THIS MANUAL AND THE SUPPLIED DEWALT® DCB118 AND BATTERY MANUAL

WORK AREA AND GENERAL SAFETY

- Read and understand the operation and maintenance manual supplied with this equipment. Keep it in a convenient place for future reference.
- This manual, together with all other manuals supplied within the kit, must be adhered to for proper and safe operation.
- Keep children and untrained personnel away from this equipment while in operation.
- Keep all guards and safety devices in place. Do not operate this equipment with guards removed or damaged.
- Keep hands, feet and loose clothing away from moving parts.
- Always stop the machine and isolate compressed air and electrical services to carry out servicing.

- Check machine before starting for worn or damaged parts. Check for signs of loose nuts and bolts etc.
- If machine is left unattended, ensure that UNAUTHORIZED use is prevented.
- Never leave the machine unattended while in use.
- Consider the use of safety barriers, especially when used in public places, observe all statutory requirements for working environments.
- Beware of pinch points involved with rotating components.
- Beware of hot surfaces, machine uses compressed air.
- When operating machine always wear appropriate safety clothing, ear protection, eye protection, hard hat, safety shoes and leather gloves, machine operates with compressed air at up to 220 PSI (15 Bar).
- Prior to installation ensure the duct route is connected properly.
- Beware of exposed electrical contacts. Do not touch or allow metal objects to come into contact.
- Machine may cause additional fire hazard if involved in an existing fire due to compressed air, and lithium batteries.
- The machine must be operated on firm ground.
- Stay clear of pressurised airline and duct.
- Only use the machine for its intended purposes.
- To retrieve fiber, blow air in the far end.
- The compressed air supply must not be allowed to enter the air chamber before the lid has been securely tightened.

- If blowing fiber from a pan, ensure the fiber exits easily from the pan, place the pan a sufficient distance to allow the operator time to react should the fiber become tangled.
- If blowing fiber from a reel, ensure the fiber reel is correctly fitted to the reel holder, using the supplied reel spacer if required.
- Fiber should be oriented to line up with the entry side of the fiber guide.
- The cable should enter the machine in a clean and dry condition.

FAILURE TO DO SO MAY RESULT IN PERSONAL INJURY OR DAMAGE TO THE BLOWN FIBER.

GENERAL PNEUMATIC SAFETY INSTRUCTIONS

The GMP Storm Blown Fiber Blowing Machine is a pneumatic device, using pressurised air to project fiber at high velocities. Please observe the following precautions when operating the Blowing Machine: -

Compressed air can cause flying debris. This could cause personal injury. Always wear personal protective equipment.

Ensure no personnel are in the manhole at the far end of the fiber run. Severe personal injury may result.

Never open the machine when pressurised.

Only AUTHORIZED, fully trained personnel should operate the air compressor.

GENERAL ELECTRICAL SAFETY INSTRUCTIONS

The machine and accessories have electronic and electrical power and control circuits. Electric shock hazards may exist that could result in severe personal injury. Observe the following precautions to avoid electrical hazards:

Do not operate in water. Do not expose the machine or any accessories to rain.

Do not disassemble the machine or any supplied accessories. There are no user serviceable parts inside. Refer servicing to qualified service personnel.

2. CRITICAL POINTS THAT DRAMATICALLY AFFECT THE OPERATION OF THE BLOWN FIBER BLOWING MACHINE

- Duct seal in air chamber correctly fitted to provide good sealing.
- Correct fiber cable guide fitted.
- Duct fully connected and pressure tested.
- Duct connecting fittings are suitable for operating at compressor supply pressure.
- Airbox lid securely tightened.
- Compressor capacity is suitable for size of duct being used.
- Fiber pan must be close to the machine; the fiber should leave the pan freely and enter the machine horizontally.
- Air chamber, drive wheels and blown fiber must be clean and free from debris, glass beads, sludge, dirt, water and lubricant.
- The fiber must be guided by hand 100ft (30m) into the machine.
- Ensure the compressed air supply is not applied to the fiber until approximately 100ft (30m) of fiber has been installed or the machine begins to slow down.
- The compressed air moisture content needs to be carefully controlled; it should be dry enough to prevent moisture forming in the ducts yet not so dry to cause a static build up – GMP recommends the use of an air dryer with a bypass.

DISCLAIMER

General Machine Products, (KT) LLC. takes care in the design of its products to ensure that the cable is protected during installation. Due to the variety and different methods of fiber manufacture the responsibility of checking the fiber compatibility with the equipment lies with the operator. Therefore, GMP cannot accept liability for any damage to the fiber.

3. GENERAL DESCRIPTION

The Storm has been developed to provide a simple to use and reliable fiber blowing solution. The Storm is designed to fit a fiber up to 3mm diameter, thereby providing the complete range of blown fiber installation solutions from one machine.

The Storm is a compact handheld integrated fiber blowing machine benefiting from automation and fiber management; electronic torque control is implemented to ensure the fiber mechanical and optical integrity is maintained. The machine only requires a single DEWALT® battery and compressed air to operate.

GMP has designed a range of accessories aimed at providing the complete solution to blown fiber installation.

4. SPECIFICATION

Fiber Compatibility: up to 3mm (.118")

Blowing Speed: up to 328 ft/min (100 m/min)

Compatible Ducts: 5mm (.197") 7mm (.275"), 8mm (.315")

Pushing force: up to 6.7 lbf (30N)

Automation: Cruise controlled speed

Air Supply: 220 psi (15 Bar) max working pressure complete with suitable air conditioning (drying)

Electrical Supply: DEWALT® 20v

- 2X 2Ah Battery packs and battery charger supplied as standard.

Control: manual trigger operated speed control, max speed and max torque limit settable

Machine size: H: 11.4" (290mm) D: 4.3" L: 6.2" (155mm)
4 lbs (1.8kg) with supplied battery installed

Case size: H: 8.1" (206mm) D: 16.8" (428mm) x L: 20.6" (524mm)

Environment: 32° to 122°F (0°C to +50°C) (Usage)
14° to 158°F (-10C to +70C) (Storage)

5. MAJOR ELEMENTS

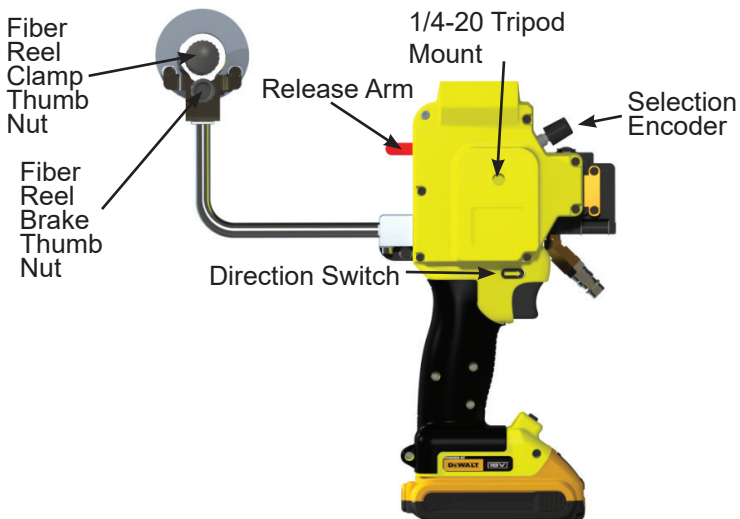
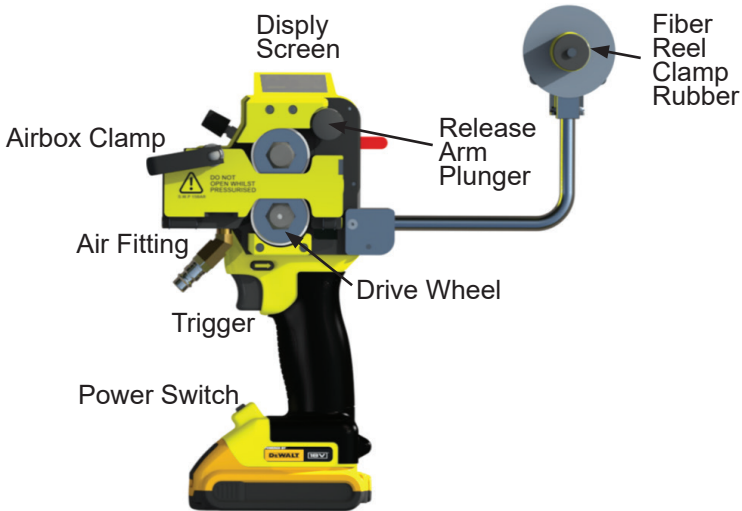

CONTROLS

On/Off switch, slide right to power unit on. Unit should be powered off when not in use or stored to prevent battery drain.



Selection Encoder knob, while unit is idle, turn clockwise/ counter clockwise to adjust setting, short press to cycle between settings, long press to reset distance counter.

While unit is running press to engage cruise control, release trigger, the unit will run at the set speed until it receives an input from the user either by pressing the encoder knob again or actuating the trigger.

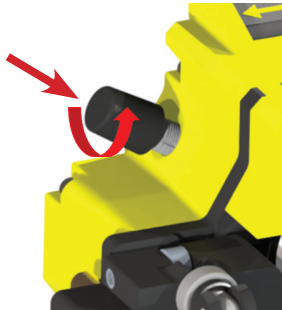

Trigger, press to increase speed up to preset speed limit.

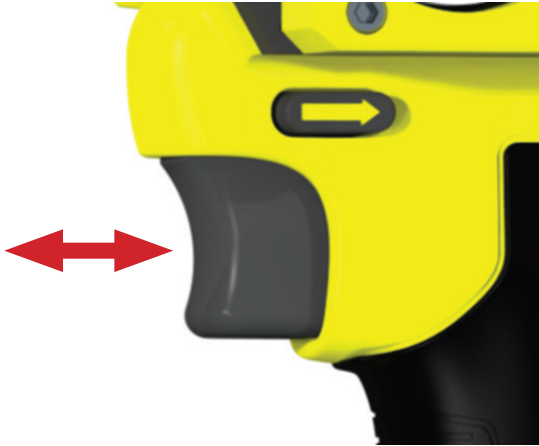

Direction selection switch, press to select machine pushing direction. Switch center position will lock the trigger and stop the unit from operating the drive wheels.



DISPLAY SCREEN

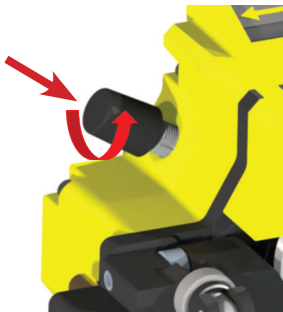

Selection Encoder knob

Selection Encoder knob

While unit is idle, turn clockwise/counter clockwise to adjust setting, short press to cycle between settings, long press to reset distance counter.

While unit is running, short press to engage cruise control. Pull trigger to disengage.

CARRY CASE LAYOUT



6. OPERATING PROCEDURE

IT IS IMPERATIVE THAT ALL PERSONS USING, OPERATING OR MAINTAINING THIS Fiber BLOWING MACHINE:

- HAVE RECEIVED COMPREHENSIVE TRAINING IN THE USE OF THIS MACHINE
- ARE COMPETENT TO USE IT,
- AUTHORIZED TO USE IT AND
- HAVE READ AND UNDERSTOOD THIS MANUAL

GMP CANNOT BE HELD RESPONSIBLE FOR MISUSE OF THIS EQUIPMENT.

SETTING UP THE DUCT AND FIBER

To begin an installation first we must connect the duct and fit the fiber through the machine. A selection of changeable parts is available to suit different sized fiber. Please consult section 12 for a list of available parts.



Firstly, it is beneficial and recommended to install a fiber blowing bead onto the end of the fiber. Place the bead over the end of the fiber and use a small set of pliers to gently crimp it in place. Try to deform the bead as little as possible while holding it in place.

Fit either the reel holder or the pigtail to the machine depending on whether you are using fiber from a reel or a pan.

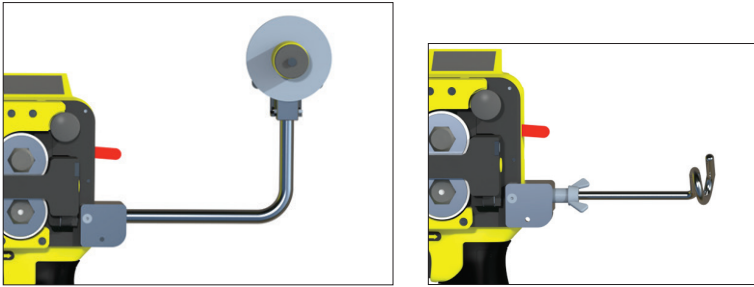

If the reel holder is being used, ensure the fiber reel is fitted tightly over the clamp rubber and the clamping screw is tightened via the thumb nut, if necessary, use the provided reel spacer on the inside of the reel to ensure a good fit.

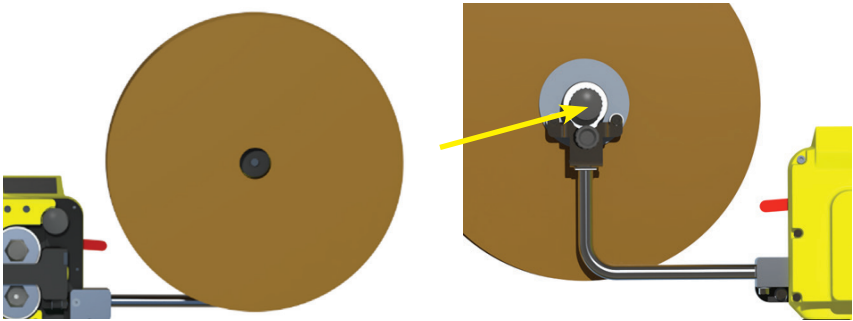

Reel back-tension can be adjusted using the fiber reel brake thumb screw on the reel holder, it should be set just tight enough to stop the reel over-running when the drive wheels stop.

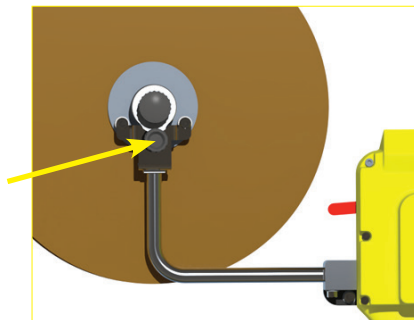

Select the appropriate size of fiber seal and fiber guide, the fiber should fit with very little resistance, fit the seal to the fiber and insert into rear fiber guide, fit the fiber guide halves together ensuring fiber moves freely through guide.

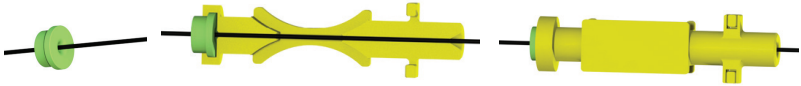

Ensure the drive wheels are in the open position by lifting the release arm upwards until the plunger clicks into place, insert the fiber guide into the airbox.

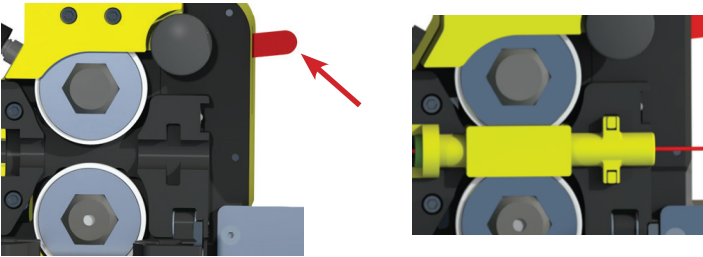

Locate the duct into the clamping teeth and seal, the Storm airbox has 3 duct OD sizes available, 8mm, 7mm, 5mm. push a short amount of fiber into duct end before closing the airbox.

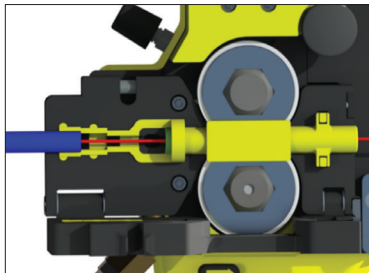

Close the airbox and clamp securely using the quick release lever pictured.

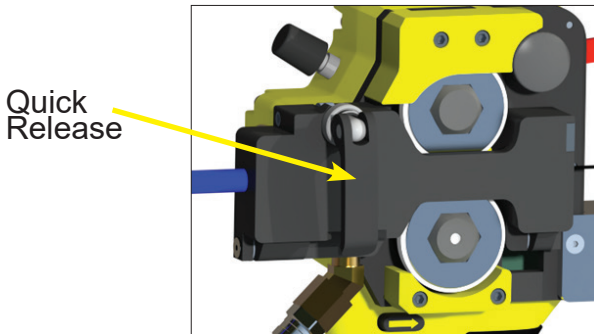

Lift and hold the clamping lever and pull the release plunger pictured. Lower the lever gently to clamp the tires onto the fiber.

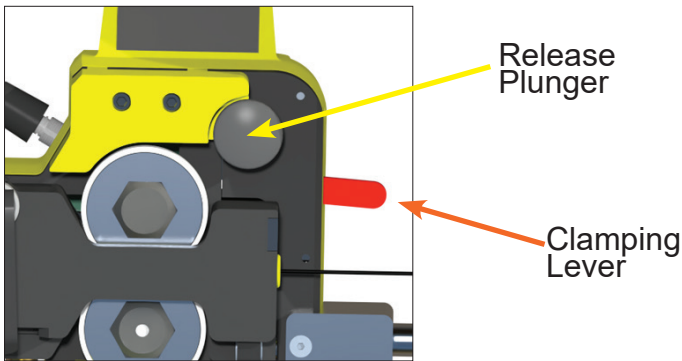

When performing an installation of a fiber cable it is important to always ensure the integrity of the fiber during the installation, it is crucial a crash test is performed. This test will provide the installer with the maximum torque setting for the machine such that if the fiber hits a blockage at speed, the fiber will not be damaged.

DETERMINING MAXIMUM TORQUE SETTING

- Set the machine up as per above.
- Instead of attaching to the installation route use a 5m length of the same duct. Use a stop end kit to block the end of the duct.
- Set the speed to the maximum installation speed to be used.
- Set the torque to 10%.
- Press and hold the trigger the machine will now accelerate to the speed setting.
- When the fiber hits the end stop the machine will either stop and leave the fiber undamaged or continue to install and break the fiber, in either case release the trigger to prevent the machine from trying to continue the install. Adjust the torque setting as appropriate for the outcome of the previous test and perform the test again, through several iterations a torque setting just below the value which would break the fiber should become apparent.

FIBER INSTALLATION

Once the machine is setup following the procedure outlined perviously, turn the machine on using the power switch located on the battery housing.

Attach needle valve assembly to air fitting and Air hose to needle valve assembly.

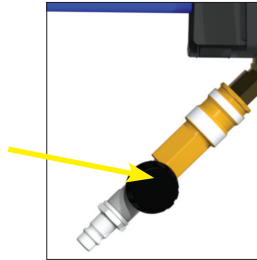

Select the maximum Speed and Torque settings appropriate for the fiber being installed. Select direction with direction selection switch.

Start the installation by slowly pulling the trigger to build up speed, do not introduce air until at least 50-65ft (15-20m) of fiber has entered the duct, as resistance increases it will be necessary to introduce airflow in to the duct, slowly introduce an amount of air using the knob located on the needle valve assembly until the fiber install speed is fairly consistent.

Air should be added in stages, using too much air too quickly will likely reduce blowing efficiency and decrease maximum distance achievable. Once the speed starts to slow or the machine sounds laboured introduce more air and repeat.

DO NOT EXCEED THE MAXIMUM SYSTEM PRESSURE OF 220 PSI (15 BAR) OR OPEN THE MACHINE WHEN UNDER PRESSURE, SERIOUS INJURY MAY RESULT.

Cruise control may be used to take over the trigger control from the operator, pull the trigger and hold at the desired speed, a short press on the trigger will engage cruise control which will be indicated by the symbol on the display screen being present.



The operator may now release the trigger, and the machine will carry on operating at the same preset. To disengage cruise control, the operator may press the encoder button, and the machine will slow to a stop, alternatively the operator can pull the trigger and take back control of the speed.

7. MAINTENANCE

The GMP Storm Blown Fiber Blowing Machine has been designed to give reliable, trouble free service over long periods. The machine requires no sophisticated maintenance procedures; simple common-sense checks and precautions are all that are needed.

The main source of breakdown and/or malfunction of a machine being used outdoors is contamination by the elements, this contamination may be introduced into the machine in a number of different ways.

The most likely may be mud, dust or other contaminants carried into the machine on the fiber. However, glass beads from EPFU fiber may also contaminate the machine.

The machine may be set down on a muddy surface or be splashed by road going vehicles when it is being used by the roadside.

The machine should be returned to the manufacturer after every 65 miles (100km) of use (or at intervals of 12 months) for a major service. The service will include the following.

- Strip down the machine.
- Clean and inspect all parts for damage, replace as necessary.
- Check all screws and fixings for damage, replace as necessary.
- Check all bearings for smooth running, replace as necessary.
- Check all electrical connections for continuity and damage, remake connections and/or replace connectors as necessary.
- Rebuild the machine, to current build standard.
- Test

8. PROCEDURE FOR REPLACING TIRES

To replace the drive tires, remove the top guard by removing the 2.5mm screws.

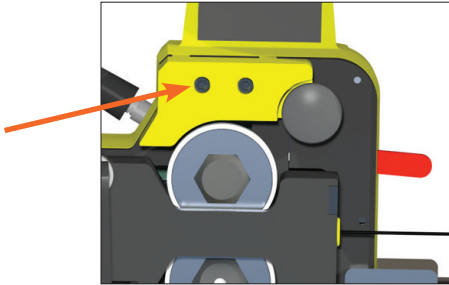

Remove the drive wheels from the hubs by pulling the wheel outwards away from the main unit.

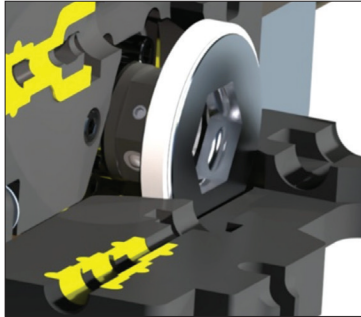

Once removed from the unit gently stretch the tires off the outer edge of the hub to replace. The wheels can be refitted either way round and to either hub.

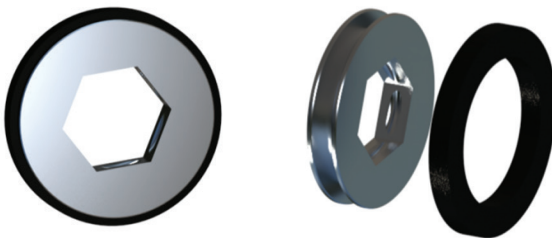

9. TROUBLESHOOTING GUIDE

1. Air loss from the Storm machine is greater than normal:

- Ensure the correct changeable parts are fitted for the fiber being used.
- Check airbox duct seal; replace if necessary.

2. Little or no airflow is exiting the duct:

- Check compressor output (refer to manufacturers handbook)
- Installation route may be too complex for installation.
- Route length is too long.
- There may be a partial blockage in the duct.
- The duct may be crushed somewhere along the route.

3. Fiber 'rides' out from between the drive wheels:

- Different sized tires may be needed for improved guidance – follow section 10 for details on changing tires.
- Incorrect fiber guide fitted
- Incorrect seal fitted

4. Fiber installation speed is very slow:

- Static build up – switch the compressor from dry air to by-pass mode (if available).
- Moisture build up – ensure compressor is running in dry air mode or check dryer operation.

5. Fiber buckles often:

- Installation route may be too complex for installation.
- The duct route may be damaged/blocked.
- Increase air pressure if possible.
- Manually slow the installation speed slightly.

6. Machine won't run:

- Check battery charge state.

7. No drive/Drive wheel slipping:

- Different tires may be needed for improved grip – follow section 8 for details on changing tires.
- Tires may be excessively worn – install new tires.

10. MONTHLY SERVICE – CHECK LIST

This section is included in the manual for your convenience, there follows a list of suggested checks, it is recommended that these checks be carried out on a regular basis, depending on use. Monthly checks are convenient; a few minutes can be set aside on the same day of each month to complete these simple checks.

- Check the carry case, ensure all tools and interchangeable parts are present, clean and ready for use.
- Clean the outside of the machine; take care not to damage the display screen, buttons, dials.
- Inspect air and electrical connections for damage.
- Inspect drive tires for wear; replace if necessary.
- Check quantities of consumable items such as blowing beads, fiber guides, and cable seals.

11. SERVICE HISTORY RECORD

Service #	Date	Carried out by	Record of Service/Repair

CABLE SEAL AND GUIDE CHART

Cable Size	Cable Seals 91004 - XX						Cable Guide 91005 - XX			
	12	16	20	23	26	30	12	18	24	30
1.0	Yellow						Orange			
1.1	Yellow						Orange			
1.2	Yellow						Orange			
1.3		Yellow						Orange		
1.4		Yellow						Orange		
1.5		Yellow						Orange		
1.6		Yellow						Orange		
1.7			Yellow					Orange		
1.8			Yellow					Orange		
1.9			Yellow						Orange	
2.0			Yellow						Orange	
2.1				Yellow					Orange	
2.2				Yellow					Orange	
2.3				Yellow					Orange	
2.4					Yellow				Orange	
2.5					Yellow					Orange
2.6					Yellow					Orange
2.7						Yellow				Orange
2.8						Yellow				Orange
2.9						Yellow				Orange
3.0						Yellow				Orange

12. SPARE PARTS

91001	Drive Wheel
91002	Drive Tire Kit 10/PK
91003	Airbox/Duct Seals 5/PK
91004-12	Cable Seals 1.0-1.2MM 10/PK
91004-16	Cable Seals 1.3-1.6MM 10/PK
91004-20	Cable Seals 1.7-2.0MM 10/PK
91004-23	Cable Seals 2.1-2.3MM 10/PK
91004-26	Cable Seals 2.4-2.6MM 10/PK
91004-30	Cable Seals 2.7-3.0MM 10/PK
91005-12	Infeed Guides 1.2MM
91005-18	Infeed Guides 1.8MM
91005-24	Infeed Guides 2.4MM
91005-30	Infeed Guides 3.0MM
91007	Cable Spool Holder Kit
91008	Cable Pigtail Holder

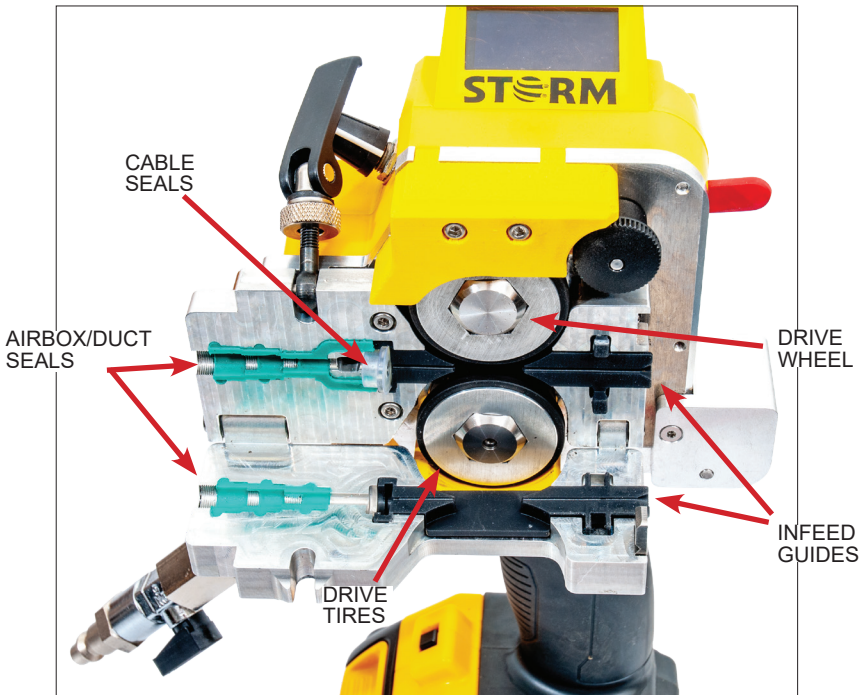



GMP • 3111 Old Lincoln Hwy • Trevose, PA 19053 • USA
TEL: +1-215-357-5500 • www.gmptools.com

DEWALT®

XR®

www.DEWALT.com



BATTERIES AND CHARGERS



WARNING: To reduce the risk of injury, read the instruction manual for the battery operated DEWALT product.

Definitions: Safety Guidelines

The definitions below describe the level of severity for each signal word. Please read the manual and pay attention to these symbols.



DANGER: Indicates an imminently hazardous situation which, if not avoided, **will** result in **death or serious injury**.



WARNING: Indicates a potentially hazardous situation which, if not avoided, **could** result in **death or serious injury**.



CAUTION: Indicates a potentially hazardous situation which, if not avoided, **may** result in **minor or moderate injury**.

NOTICE: Indicates a practice **not related to personal injury** which, if not avoided, **may** result in **property damage**.



Denotes risk of electric shock.



Denotes risk of fire.

Chargers

DEWALT chargers require no adjustment and are designed to be as easy as possible to operate.

Electrical Safety



Your DEWALT charger is double insulated; therefore, no earth wire is required.

If the supply cord is damaged, it must be replaced only by DEWALT or an authorised service organisation.

Mains Plug Replacement (U.K. & Ireland Only)

If a new mains plug needs to be fitted:

- Safely dispose of the old plug.
- Connect the brown lead to the live terminal in the plug.
- Connect the blue lead to the neutral terminal.



WARNING: No connection is to be made to the earth terminal.

Follow the fitting instructions supplied with good quality plugs. Recommended fuse: 3 A.

Using an Extension Cable

An extension cord should not be used unless absolutely necessary. Use an approved extension cable suitable for the power input of your charger (Refer to **Technical Data** in your product or charger manual). The minimum conductor size is 1 mm²; the maximum length is 30 m.

When using a cable reel, always unwind the cable completely.

Important Safety Instructions for All Battery Chargers

SAVE THESE INSTRUCTIONS: This manual contains important safety and operating instructions for DEWALT battery chargers. Refer to **Technical Data** in your product or charger manual for more information. Before using the charger, read all instructions and cautionary markings on the charger, battery pack and product using the battery pack.



WARNING: Shock hazard. Do not allow any liquid to get inside charger. Electric shock may result.



WARNING: We recommend the use of a residual current device with a residual current rating of 30 mA or less.



CAUTION: Burn hazard. To reduce the risk of injury, charge only DEWALT rechargeable batteries. Other types of batteries may burst, causing personal injury and damage.



WARNING: DEWALT chargers are not intended for use by persons (including children) with reduced physical, sensory or mental capabilities, or lack of experience and knowledge, unless they have been given supervision or instruction concerning use of the appliance by a person responsible for their safety.



CAUTION: Children should be supervised to ensure that they do not play with the appliance.

NOTICE: Under certain conditions, with the charger plugged into the power supply, the exposed charging contacts inside the charger can be shorted by foreign material. Foreign materials of a conductive nature such as, but not limited to, steel wool, aluminum foil or any buildup of metallic particles should be kept away from charger cavities. Always unplug the charger from the power supply when there is no battery pack in the cavity. Unplug charger before attempting to clean.

- **DO NOT attempt to charge the DEWALT battery with any charger other than the DEWALT charger in which the battery fits.** DEWALT chargers are not intended for any uses other than charging DEWALT rechargeable batteries. DEWALT chargers and DEWALT battery packs are specifically designed to work together. Any other uses may result in risk of fire, electric shock or electrocution.
- **Do not expose charger to rain or snow.** Water entering a product will increase the risk of electric shock.
- **Pull by plug rather than cord when disconnecting the charger.** This will reduce risk of damage to electric plug and cord.
- **Do not operate charger with damaged cord or plug—** have them replaced immediately.
- **Position units so that cables do not cross footpaths or are in the work area. This prevents the risk of tripping over the cable or damaging the cable by stepping on it.**
- **Do not use an extension cord unless it is absolutely necessary.** Use of improper extension cord could result in risk of fire, electric shock, or electrocution.

- **Do not place any object on top of charger or place the charger on a soft surface that might block the ventilation slots and result in excessive internal heat.**
Place the charger in a position away from any heat source. The charger is ventilated through slots in the top and the bottom of the housing.
- **Do not operate charger if it has received a sharp blow, been dropped, or otherwise damaged in any way.** Take it to an authorised service centre.
- **Do not disassemble charger; take it to an authorised service centre when service or repair is required.** Incorrect reassembly may result in a risk of electric shock, electrocution or fire.
- **Disconnect the charger from the outlet before attempting any cleaning. This will reduce the risk of electric shock.**
Removing the battery pack will not reduce this risk.
- **NEVER** attempt to connect two chargers together.

Charging a Battery

NOTE: Refer to the label near indicator light(s) on charger for on/off and blink patterns. Older chargers may have additional information and/or may not have a yellow indicator light, being equipped with only a single red indicator light.









1. Plug the charger into an appropriate outlet before inserting battery pack.
2. Insert and fully seat battery pack. The left indicator light will continuously blink red to indicate that the charging process has started. For two-stage chargers, this is indicative of Stage 1 charging during which the battery pack is charged to a majority of its capacity.
3. Charging is complete for a single-stage charger when the left indicator light remains continuously red and the right indicator light stays unlit. For a two-stage charger, the left indicator light remains continuously red and the right indicator light continuously blinks red to indicate stage 2 charging during which the battery pack is topped off to its full capacity. Stage 2 charging is complete when both indicator lights remain continuously red. After charging is complete, the battery pack may be removed and used, or left in the charger.

The charger will not charge a faulty battery pack. The charger refusing to light could indicate a problem with the charger or a faulty battery pack. Discontinue use and take both to an authorised service centre.





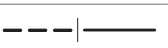







NOTE: To remove the battery pack, some chargers require the battery pack release button to be pressed.

WARNING: Only charge batteries in air temperature over 4 °C and below 40 °C.

Single Stage Charger Indicators

	Charging		
	Fully Charged		
	Hot/Cold Pack Delay		

Two Stage Charger Indicators

	Stage 1 Charging		
	Stage 2 Charging		
	Fully Charged		
	Hot/Cold Pack Delay		

Hot/Cold Pack Delay

When the charger detects a battery pack that is too hot or too cold, it automatically starts a Hot/Cold Pack Delay, suspending charging until the battery pack has reached an appropriate temperature. The charger then automatically switches to the pack charging mode. This feature ensures maximum battery pack life.

A cold battery pack will charge at a slower rate than a warm battery pack. The battery pack will charge at that slower rate throughout the entire charging cycle and will not return to maximum charge rate even if the battery pack warms.

Some chargers are equipped with an internal fan designed to cool the battery pack. The fan will turn on automatically when the battery pack needs to be cooled. Never operate the charger if the fan does not operate properly or if ventilation slots are blocked. Do not permit foreign objects to enter the interior of the charger.

Electronic Protection System

XR Li-ion products are designed with an Electronic Protection System that will protect the battery pack against overloading, overheating or deep discharge.

The product will automatically turn off if the Electronic Protection System engages. If this occurs, place the Li-ion battery pack in the charger until it is fully charged.

Wall Mounting

These chargers are designed to be wall mountable or to sit upright on a table or work surface. If wall mounting, locate the charger within reach of an electrical outlet, and away from a corner or other obstructions which may impede air flow. Use the back of the charger as a template for the location of the mounting screws on the wall. Mount the charger securely using drywall screws (purchased separately) at least 25.4 mm long with a screw head diameter of 7–9 mm, screwed into wood to an optimal depth leaving approximately 5.5 mm of the screw exposed. Align the slots on the back of the charger with the exposed screws and fully engage them in the slots.

Charger Cleaning Instructions

WARNING: Shock hazard. Disconnect the charger from the AC outlet before cleaning. Dirt and grease may be removed from the exterior of the charger using a cloth or soft non-metallic brush. Do not use water or any cleaning solutions. Never let any liquid get inside the product; never immerse any part of the product into a liquid.

Battery Packs



WARNING: Use only DeWALT batteries in DeWALT products, or products officially intended to be powered by DeWALT batteries.

Important Safety Instructions for All Battery Packs

When ordering replacement battery packs, be sure only battery packs of the correct voltage recommended in the instruction manual of the end product shall be used.

The battery pack is not fully charged out of the carton. Before using the battery pack and charger, read the safety instructions below. Then follow charging procedures outlined.

READ ALL INSTRUCTIONS

- **Do not charge or use battery in explosive atmospheres, such as in the presence of flammable liquids, gases or dust.** Inserting or removing the battery from the charger may ignite the dust or fumes.
- **Never force battery pack into charger. Do not modify battery pack in any way to fit into a non-compatible charger as battery pack may rupture, causing serious personal injury.**
- Charge DeWALT battery packs only in DeWALT chargers.
- **DO NOT splash or immerse in water or other liquids.**
- **Do not store or use the product and battery pack in locations where the temperature may fall below 4 °C (39.2 °F) (such as outside sheds or metal buildings in winter), or reach or exceed 40 °C (104 °F).**
- **Do not incinerate the battery pack even if it is severely damaged or is completely worn out.** The battery pack can explode in a fire. Toxic fumes and materials are created when lithium-ion battery packs are burned.
- **If battery contents come into contact with the skin, immediately wash area with mild soap and water.** If battery liquid gets into the eye, rinse water over the open eye for 15 minutes or until irritation ceases. If medical attention is needed, the battery electrolyte is composed of a mixture of liquid organic carbonates and lithium salts.
- **Contents of opened battery cells may cause respiratory irritation.** Provide fresh air. If symptoms persist, seek medical attention.
- **Keep battery packs out of the reach of children.**



WARNING: Burn hazard. Battery liquid may be flammable if exposed to spark or flame.



WARNING: Never attempt to open the battery pack for any reason. If battery pack case is cracked or damaged, do not insert into charger. Do not crush, drop or damage battery pack. Do not use a battery pack or charger that has received a sharp blow, been dropped, run over or damaged in any way (i.e., pierced with a nail, hit with a hammer, stepped on). Electric shock or electrocution may result. Damaged battery packs should be returned to service centre for recycling.



WARNING: Fire hazard. Do not store or carry the battery pack so that metal objects can contact

exposed battery terminals. For example, do not place the battery pack in aprons, pockets, product boxes, product kit boxes, drawers, etc., with loose nails, screws, keys, etc.



CAUTION: When not in use, place product on its side on a stable surface where it will not cause a tripping or falling hazard. Some products with large battery packs will stand upright on the battery pack but may be easily knocked over.

Transportation



WARNING: Fire hazard. Transporting batteries can possibly cause fire if the battery terminals inadvertently come into contact with conductive materials. When transporting batteries, make sure that the battery terminals are protected and well-insulated from materials that could contact them and cause a short circuit. **NOTE:** Lithium-ion batteries should not be put in checked baggage.

DeWALT batteries comply with all applicable shipping regulations as prescribed by industry and legal standards, which include UN Recommendations on the Transport of Dangerous Goods; International Air Transport Association (IATA) Dangerous Goods Regulations; International Maritime Dangerous Goods (IMDG) Regulations; and the European Agreement Concerning The International Carriage of Dangerous Goods by Road (ADR).

In most instances, shipping a DeWALT battery pack will be excepted from being classified as a fully regulated Class 9 Hazardous Material. In general, only shipments containing a lithium-ion battery with an energy rating greater than 100 Watt Hours (Wh) will require being shipped as fully regulated Class 9. All lithium-ion batteries have the Wh rating marked on the pack. Furthermore, due to regulation complexities, DeWALT does not recommend air shipping lithium-ion battery packs alone regardless of Wh rating. Shipments of products with batteries (combo kits) can be air shipped as excepted if the Wh rating of the battery pack is no greater than 100 Wh.

Regardless of whether a shipment is considered excepted or fully regulated, it is the shipper's responsibility to consult the latest regulations for packaging, labeling/marketing and documentation requirements.

The information provided in this section of the manual is provided in good faith and believed to be accurate at the time the document was created. However, no warranty, expressed or implied, is given. It is the buyer's responsibility to ensure that its activities comply with the applicable regulations.

Transporting the FLEXVOLT™ Battery

The DeWALT FLEXVOLT® battery has two modes: **Use** and **Transport**.

Use Mode: When the FLEXVOLT™ battery stands alone or is in a DeWALT 18V product, it will operate as an 18V battery. When the FLEXVOLT™ battery is in a 54V or a 108V (two 54V batteries) product, it will operate as a 54V battery.

Transport Mode: When the cap is attached to the FLEXVOLT™ battery, the battery is in Transport mode. Keep the cap for shipping.

When in Transport mode, strings of cells are electrically disconnected within the pack, resulting in 3 batteries with a lower Watt hour (Wh) rating as compared to 1 battery with a higher Watt hour rating. This increased quantity of 3 batteries with the lower Watt hour rating can exempt the pack from certain shipping regulations that are imposed upon the higher Watt hour batteries.

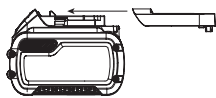

For example, the Transport Wh rating might indicate 3 x 36 Wh, meaning 3 batteries of 36 Wh each. The Use Wh rating might indicate 108 Wh (1 battery implied).

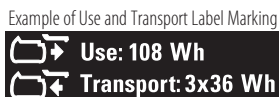

Storage Recommendations

1. The best storage place is one that is cool and dry away from direct sunlight and excessive heat or cold. For optimum battery performance and life, store battery packs at room temperature when not in use.
2. For long storage, it is recommended to store a fully charged battery pack in a cool, dry place out of the charger for optimal results.

NOTE: Battery packs should not be stored completely depleted of charge. The battery pack will need to be recharged before use.

Labels on Charger and Battery Pack

In addition to the pictographs used in this manual, the labels on the charger and the battery pack may show the following pictographs:



Read instruction manual before use.



Charging time.



Do not probe with conductive objects.



Do not charge damaged battery packs.



Do not expose to water.



Have defective cords replaced immediately.



Charge only between 4 °C and 40 °C.



Only for indoor use.



Discard the battery pack with due care for the environment.



Charge DeWALT battery packs only with designated DeWALT chargers. Charging battery packs other than the designated DeWALT batteries with a DeWALT charger may make them burst or lead to other dangerous situations.



Do not incinerate the battery pack.



USE (without transport cap). Example: Wh rating indicates 108 Wh (1 battery with 108 Wh).



TRANSPORT (with built-in transport cap). Example: Wh rating indicates 3 x 36 Wh (3 batteries of 36 Wh).

Date Code

The production date code consists of a 4-digit year followed by a 2-digit week and is extended by a 2-digit factory code.

MAINTENANCE

Your product has been designed to operate over a long period of time with a minimum of maintenance. Continuous satisfactory operation depends upon proper product care and regular cleaning.



WARNING: To reduce the risk of serious personal injury, turn product off and disconnect battery pack before making any adjustments or removing/installing attachments or accessories. An accidental start-up can cause injury.



WARNING: Cleaning and user maintenance shall not be performed by children.

The charger and battery pack are not serviceable.

Protecting the Environment



Separate collection. Products and batteries marked with this symbol must not be disposed of with normal household waste.



Products and batteries contain materials that can be recovered or recycled, reducing the demand for raw materials. Please recycle electrical products and batteries according to local provisions. Further information is available at www.2helpU.com.

Rechargeable Battery Pack

This long-life battery pack must be recharged when it fails to produce sufficient power on jobs that were easily done before. At the end of its technical life, discard it with due care for our environment:

- Run the battery pack down completely, then remove it from the tool.
- Li-Ion cells are recyclable. Take them to your dealer or a local recycling station. The collected battery packs will be recycled or disposed of properly.

Belgique et Luxembourg België en Luxemburg	DEWALT - Belgium BVBA Egide Walschaertsstraat 16 2800 Mechelen	Tel: NL 32 15 47 37 63 Tel: FR 32 15 47 37 64 Fax: 32 15 47 37 99	www.dewalt.be enduserv.BE@sbdinc.com
Danmark	DEWALT (Stanley Black&Decker AS) Roskildevej 22 2620 Albertslund	Tel: 70 20 15 10 Fax: 70 22 49 10	www.dewalt.dk kundeservice.dk@sbdinc.com
Deutschland	DEWALT Richard-Klinger-Str. 11 65510 Idstein	Tel: 06126-21-0 Fax: 06126-21-2770	www.dewalt.de infodwge@sbdinc.com
Ελλάς	DEWALT (ΕΜΔΑ) Α.Ε. ΕΔΡΑ-ΓΡΑΦΕΙΑ : Στραβωνος 7 & Α. Βουλιαμενης, Γλυφάδα 166 74, Αθήνα SERVICE : Ημερος Τοπος 2 (Κάσι Αδών) – 193 00 Ασπρόπυργος	Τηλ: 00302108981616 Φαξ: 00302108983570	www.dewalt.gr Greece.Service@sbdinc.com
España	DEWALT Ibérica, S.C.A. Parc de Negocios "Mas Blau" Edificio Muntadas, c/Bergadá, 1, Of. A6 08820 El Prat de Llobregat (Barcelona)	Tel: 934 797 400 Fax: 934 797 419	www.dewalt.es respuesta.postventa@sbdinc.com
France	DEWALT (Stanley Black & Decker France SAS) 62 Chemin de la Bruyère 69570 Dardilly, France	Tel: 04 72 20 39 20 Fax: 04 72 20 39 00	www.dewalt.fr scufr@sbdinc.com
Schweiz Suisse Svizzera	DEWALT In der Luberzen 42 8902 Urdorf	Tel: 044 - 755 60 70 Fax: 044 - 730 70 67	www.dewalt.ch service@rofoag.ch
Ireland	DEWALT Building 4500, Kinsale Road Cork Airport Business Park Cork, Ireland	Tel: 00353-2781800 Fax: 01278 1811	www.dewalt.ie Sales.ireland@sbdinc.com
Italia	DEWALT via Energypark 6 20871 Vimercate (MB), IT	Tel: 800-014353 39 039-9590200 Fax: 39 039-9590311	www.dewalt.it
Nederlands	DEWALT Netherlands BVPostbus 83, 6120 AB BORN	Tel: 31 164 283 063 Fax: 31 164 283 200	www.dewalt.nl
Norge	DEWALT Postboks 4613 0405 Oslo, Norge	Tel: 45 25 13 00 Fax: 45 25 08 00	www.dewalt.no kundeservice.no@sbdinc.com
Österreich	DEWALT Werkzeug Vertriebsges m.b.H Oberlaaerstrasse 248, A-1230 Wien	Tel: 01 - 66116 - 0 Fax: 01 - 66116 - 614	www.dewalt.at service.austria@sbdinc.com
Portugal	DEWALT Ed. D Dinis, Quina da Fonte Rua dos Malhoes 2 2A 2º Esq. Oeiras e S. Juliao da Barra, paço de Arcos e Caxias 2770 071 Paço de Arcos	Tel: +351 214667500 Fax: +351214667580	www.dewalt.pt resposta.posvenda@sbdinc.com
Suomi	DEWALT PL47 00521 Helsinki, Suomi	Puh: 010 400 4333 Faksi: 0800 411 340	www.dewalt.fi asiakaspalvelu.fi@sbdinc.com
Sverige	DEWALT BOX 94 43122 Mölndal Sverige	Tel: 031 68 61 60 Fax: 031 68 60 08	www.dewalt.se kundservice.se@sbdinc.com
Türkiye	Stanley Black & Decker Turkey Alet Üretim Tic. Ltd.Şti İçerenköy Mahallesi Umur Sokak No: 10-12 / 82-83-84 Kat: 19 Ataşehir-İstanbul, Türkiye	Tel: +90 216 665 2900 Faks: +90 216 665 2901	www.dewalt.com.tr support@dewalt.com.tr
United Kingdom	DEWALT, 270 Bath Road; Slough, Berks SL1 4DX	Tel: 01753-567055 Fax: 01753-572112	www.dewalt.co.uk emeservice@sbdinc.com
Australia / New Zealand	DEWALT 810 Whitehorse Road Box Hill VIC 3128 Australia	Tel: Aust 1800 654 155 Tel: NZ 0800 339 258	www.dewalt.com.au www.dewalt.co.nz
Middle East Africa	DEWALT P.O. Box - 17164, Jebel Ali Free Zone (South), Dubai, UAE	Tel: 971 4 812 7400 Fax: 971 4 2822765	www.dewalt.ae support@dewalt.ae